



# Universal Ceiling Projector Mount

## **A56-E25B2**

User Guide



The A56-E25B2 Projector mount is 90% compatible with most projector footprint designs. It is easy to use for low/high ceilings and short-throw wall projector installations. It can be adjusted in both length and height to optimize the right level of projection.

SPECIFICATIONS	
Max weight for ceiling and wall installation.	37.4 lbs.
Total weight of the A56-E25B2.	3 lbs.
Overall dimensions of the A56-E25B2. (L x W x H)	12.5" x 4.3" x 2.3"

Example of the A56-E25B2 with extension bar for high or angled ceilings.



Example of A56-E25B2 without extension bar for a flush mount to the ceiling.



Example of A56-E25B2 as a short-throw mount for wall installation.

# Flush Ceiling Mount

#1

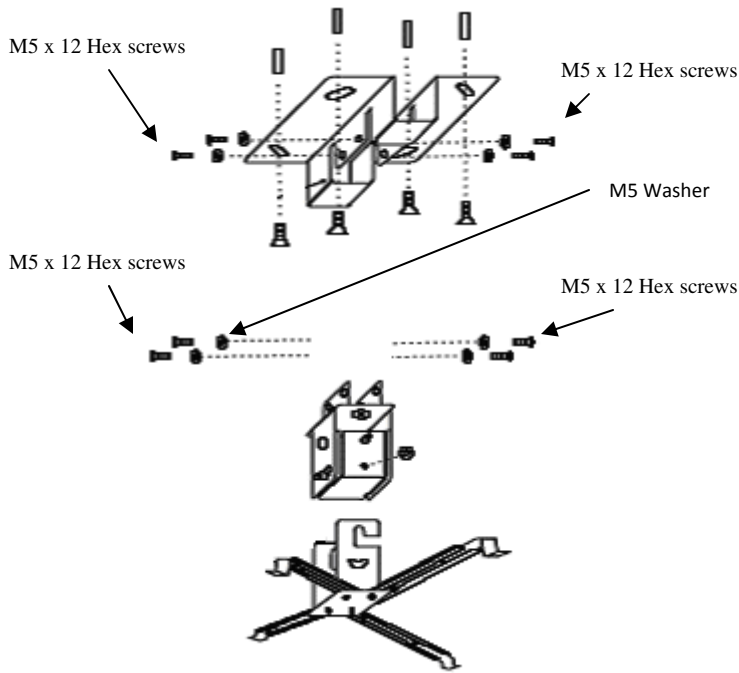

This installation is designed to bring the projector closer to the ceiling to accommodate room size. The extension does not necessarily have to be removed for the projector to be mounted. The design of this particular mount has the ability to be extended or flushed closer to the ceiling. The extra accessories can be removed and replaced with additional parts. The extra hardware is designed to fit 90% of the different projector types in the US. Some screws may be required for the projector. For proper installation, please make sure the projector has the option of being ceiling mounted. Please reference in the projector's manual for mount options. The projector mount has the capability to tilt at a 20-30% angle in a circular motion.

d



Short extension

e

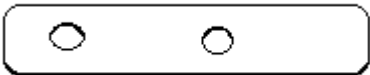

Extension for spider leg.

f



Long extension for spider leg.

These extensions are extra parts for mounting purposes. By simply removing either extension from the mount you can have it shortened or extended depending on the size and model of your projector. The spider legs are manufactured to extend if needed to provide extra extension to reach the correct mount screw. By adding extension (e) you can have the spider legs extended further for reaching the projector's screw points. Extension (d) can be placed with extension (e) by securing it with screw type (b). Extension (f) is an extra accessory; the mount has 2 extensions similar to extension (f). This will only be required if the extensions are not long enough for your projector.

# Mount assembly with extension bar

#2

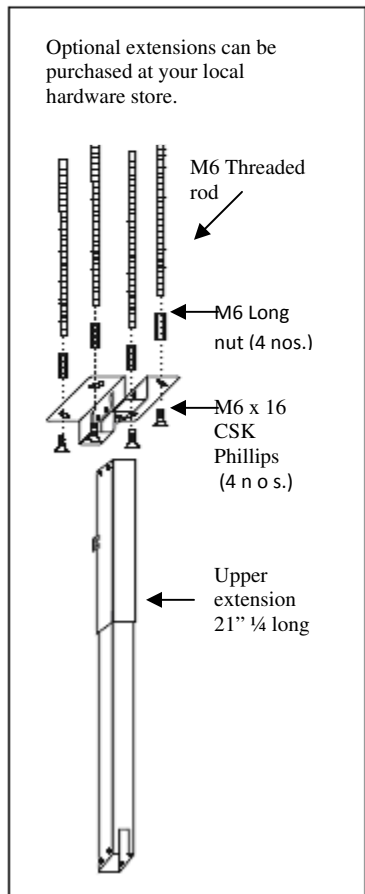
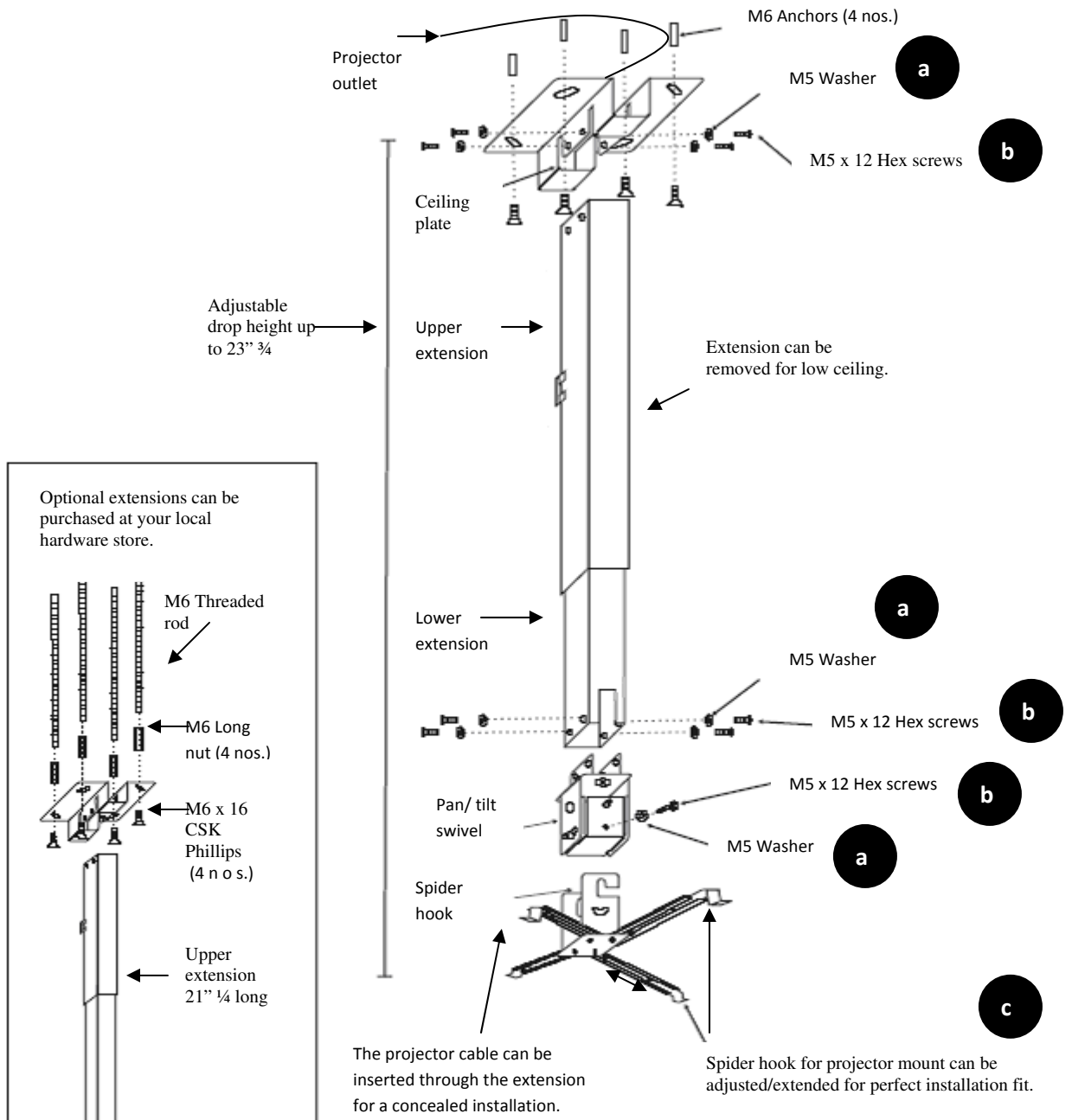

- Standard mounting screws /parts for LCD/DLP projector:
- a. M5 Washer (4 nos.)
  - b. M5 x 12 Phillip screws (4 nos.)
  - c. Spider hook for the projector mount.
  - d. Extra spider leg extension (Short).
  - e. Extension for spider leg (Long Bracket).
  - f. Extra spider leg extension (Long Extension).

# Short-throw mount assembly

#3

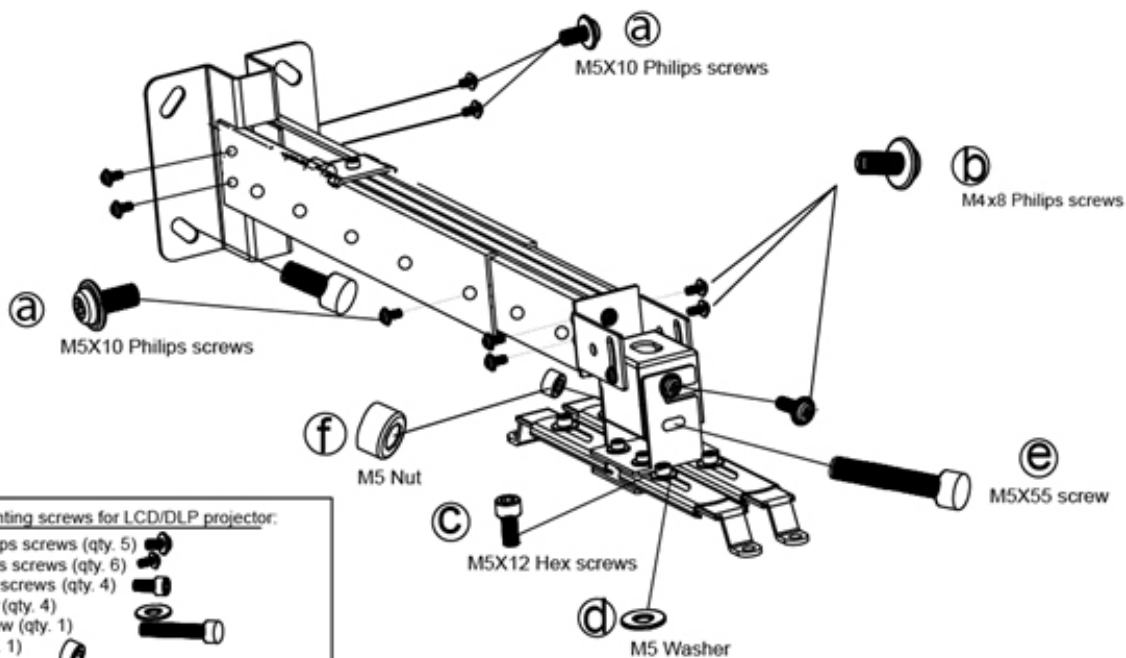

Remove the 2.5" Phillips head screw from the Pan/ Tilt Swivel to easily modify your mount to be used as a short-throw Mount. Next is to remove the Straight Blade head screws (2) from the Pan /Tilt Swivel. Connect the Spider Body to the Pan Tilt Swivel (as shown in picture), and secure with one M4x8 Phillips screw and the M5x55 screw and M5 Nut. Connect the Extension Bar to the Pan/Tilt Swivel and secure on both sides with the M4x8 Phillips screws. At the other end of the Extension Bar, connect the Wall Plate and secure with the M5x10 Phillips screws. Note: Extension Bar will need to be adjusted to connect to the Pan/Tilt Swivel and the Wall Plate. After connecting the Spider Legs to the Spider Body, the mount is ready to be attached to the projector and mounted directly to the wall or on the optional ZA56-WP (Wall Plates).



Optional ZA56-WP  
(wall plate mount for short-throw wall mount on wood studs)  
Available at [www.shop.elitescreens.com](http://www.shop.elitescreens.com)

# Warranty Policy

- **Two (2) year** parts and labor warranty from defects in workmanship from purchase date as follows (except for refurbished units as specified below):
- **Three (3) year** parts and labor warranty from defects in workmanship for **GEMR** (Government, Educational, Military, & Religious) purchases of new product only.
- **Refurbished units** carry a **90-day** parts and labor warranty.
- Each party will be responsible for one way shipping during the warranty period.
- **A RMA (Return Merchandise Authorization) number** must be issued in order to process a replacement or to authorize a return for warranty repair. Elite Screens will, at its sole option replace or repair the defective unit with a replacement \*(see exceptions below) after the defective unit is received. Once the product is received, Elite Screens will send out a replacement \*unit to the customer by ground service (subject to inventory availability).
- **Do not return any unauthorized items to Elite Screen, as they will be refused and returned at your expense. The RMA number must be included on the outside label of your shipping box. Our warehouse is not authorized to accept returns without an RMA number on the shipping label.**
- **RMA numbers are valid for 45 days from the date of issue.**
- **Missing Parts** must be reported within 7-days of receipt. If reported after 7 days, customer will only be responsible for shipping and handling fees. If reported after 30 days of receipt, customer is responsible for cost of the parts and shipping & handling fees.

\*A new or refurbished replacement will be sent out to the customer depending on the type of purchase (New or refurbished) based on stock availability.

## **North America only, U.S. and Canada**

For Warranty and Service requests please fill out a RMA /Service Form at:

[www.elitescreens.com/warrantysupportform](http://www.elitescreens.com/warrantysupportform)

Please Visit this link for full Warranty information: <http://www.elitescreens.com/warranty>

For Customer Service and Technical questions, please contact Elite Screens at:

Telephone: (877) 511-1211

Fax: (562) 926-8433

REMEMBER TO REGISTER YOUR PRODUCT AT

**[WWW.ELITESCREENS.COM/REGISTER](http://WWW.ELITESCREENS.COM/REGISTER)**

# Contact Info

US & Canada Tech Support & Warranty Claim

Please contact us at [service@elitescreens.com](mailto:service@elitescreens.com) or call +1 877-511-1211 #3 Service or fax +1 562-926-8433

Europe Tech Support & Warranty Claim

Please contact us at [service@elitescreens.eu](mailto:service@elitescreens.eu) or call +49-(0) 40-30392958

Asia Tech Support & Warranty Claim

Please contact us at [service@elitescreens.com.cn](mailto:service@elitescreens.com.cn) or call +86-(0) 755-8461-7989

Taiwan Tech Support & Warranty Claim

Please contact us at [service@elitescreens.com.tw](mailto:service@elitescreens.com.tw) or call +886+2+8990-1999

## America:

### Elite Screens Inc

16410 Manning Way

Cerritos, CA 90703 USA

Tel: +1-562-483-8198 (877-511-1211)

Fax: +1-562-926-8433

[info@elitescreens.com](mailto:info@elitescreens.com)

[www.elitescreens.com](http://www.elitescreens.com)

## China:

### Elite Screens China Corp.

Longxi Duimianling Industry Zone

Longcheng Longgang District, ShenZhen

GuangDong, China

Tel: +86-(0)755-8461-7989

Fax: +86-(0)755-8461-7669

[info@elitescreens.com.cn](mailto:info@elitescreens.com.cn)

[www.elitescreens.com.cn](http://www.elitescreens.com.cn)

## Asia

### Elite Screens Taiwan Corp.

4F., No. 42-1 Wuguan Rd. Wugu Township Taipei

County 248, Taiwan (Wugu Industrial Park)

Taiwan (R.O.C)

Tel: + 886+2+8990-1999

Fax: + 866+2+8990+1366

[info@elitescreens.com.tw](mailto:info@elitescreens.com.tw)

[www.elitescreens.com.tw](http://www.elitescreens.com.tw)

## Europe:

### Elite Screens Europe

Lübecker Straße 1

22087 Hamburg, Germany

Tel: +49-40-30392494

Fax: +49-40-49219200

[info@elitescreens.eu](mailto:info@elitescreens.eu)

[www.elitescreens.eu](http://www.elitescreens.eu)

### Elite Screens France S.A. S

11, Allée William Penn

92150 Suresnes, France

Tel: +33-1-45064735

Fax: +33-1-45064735

[info.fr@elitescreens.com](mailto:info.fr@elitescreens.com)

[www.elitescreens.com/fr](http://www.elitescreens.com/fr)

### Latin America Contact

[info.la@elitescreens.com](mailto:info.la@elitescreens.com)

### East Asia Contact

[info.ea@elitescreens.com](mailto:info.ea@elitescreens.com)

### India Contact

[info.india@elitescreens.com](mailto:info.india@elitescreens.com)

### Japan Contact

[info.japan@elitescreens.com](mailto:info.japan@elitescreens.com)