



# Insta-DEM Series

## Magnetic Dry-Erase Front Projection Screen

### User's Guide

Thank you for choosing the Insta-DEM Series dry-erase whiteboard projection screen! Please read through this user guide before utilizing the screen. Correct usage and maintenance will ensure a long product life.

#### **Precautionary Notes:**

Before using the dry-erase function of your whiteboard screen, please make note of the following instructions to properly maintain and clean your dry-erase surface projection screen. (These Whiteboard cleaning tips are just as relevant with any dry-erase writing surface as they are with our Whiteboard-Projection Screens.)

1. Only use a high density foam eraser when removing dry-erase markings from the Whiteboard screen.
2. Do not use abrasive erasers as these may scratch the surface of the screen.
3. Never spray the whiteboard cleaner solution onto the surface while marker writing is present and then attempt to use a high density foam eraser to remove. This will only smear the dry-erase marker ink making the surface more difficult to clean and will likely ruin the foam eraser.
4. If there are any dry-erase markings left behind even after attempting to remove them using our high density erasers, spray our whiteboard cleaning solution directly onto the screen surface and use only a soft microfiber cloth to wipe-down and clean the area.

For a video demonstration, please visit: <http://www.elitescreens.com/whiteboardscreen-cleaning>

If replacement cleaning accessories are needed, please visit the Whiteboard cleaning accessories section of our website at <http://www.elitescreens.com/clean-whiteboard>

## Product Features

- Award winning and GREENGUARD certified VersaWhite material.
- 1.1 gain with 180 degree wide viewing angle.
- Special anti-scratch layer to ensure long use as a dry-erase/projection screen.
- Anti-reflection diffusion surface eliminates glare and hot-spot while using a projector.
- Magnetic backing allows installation on ferromagnetic surfaces (no tools required)

## Application Advantages

- Instantly converts ferromagnetic surfaces or walls into a dry-erase whiteboard projection screen.
- Perfect dry-erase and projection solution for today's short throw projectors.
- Ideal and effective instructional presentation tool in the classroom, boardroom, and training facilities.

## What's in the package

Please make sure all parts listed below are included. If anything is missing please contact us immediately.

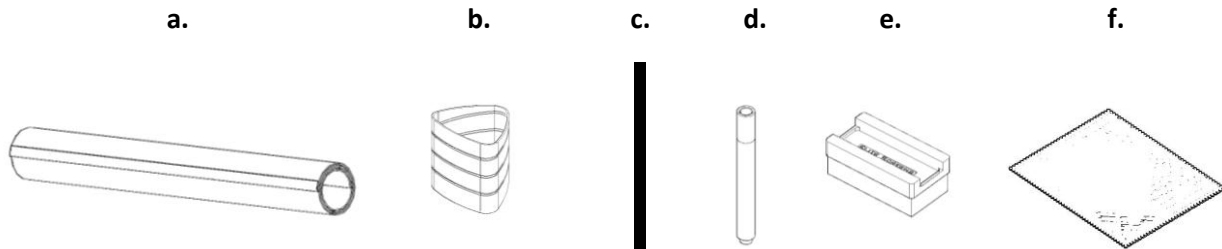

Parts List	QTY
a. Insta-DEM Screen Material	1
b. Pen Holder	1
c. Magnetic bar	2
d. Whiteboard markers	3
e. Elite special high density eraser	2
f. Microfiber cleaning cloth	1

### Notes:

1. For best results and maximum product longevity, ***ONLY*** use *Elite Screens high density whiteboard Eraser*
2. Please use the microfiber cloth and clean water to cleanse the surface every 2-4 weeks to maintain a fresh and clean projection surface.

# Installation

**Attention:** Prolonged storage of the Insta-DEM in its factory packaging *may result* in the material not being able to lie flat once removed from its tube. An easy way to remedy this is to remove the material from the tube and roll it up in a reverse manner for 5 minutes. This will flatten out the material and make it more pliable to work with.

1. Clean the magnetic surface location where the **Insta-DEM Screen** will be installed.
2. Measure and mark the top-right and bottom-right corner of the installation location.

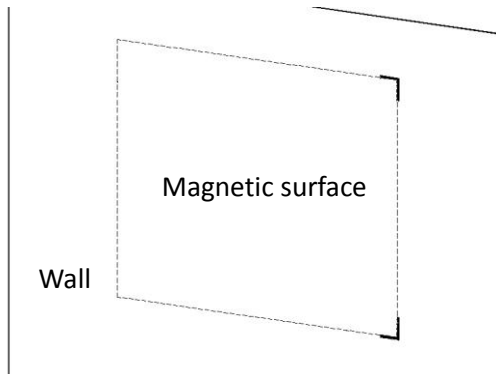

3. Attach the Insta-DEM Screen to the top-right and bottom-right corner of the magnetic surface location as shown below.

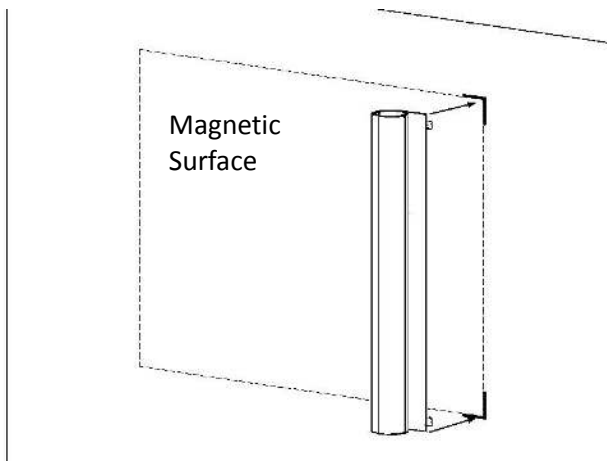

4. Carefully unroll the material and firmly attach the top and bottom until the Insta-DEM Screen is completely attached to the magnetic surface.

- Secure the edges by placing the magnetic bar on the left and right side of the Insta-DEM Screen. This allows the material to lay flat on the magnetic surface.

**Note:**

The magnetic bars can be removed once the Insta-DEM screen material is securely attached to the magnetic surface.

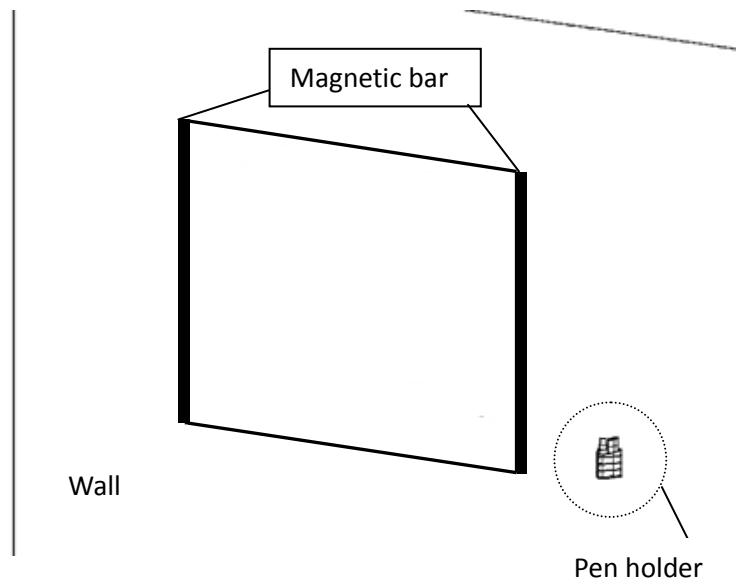

- Peel the tape strip off the back of the pen holder and attach the pen holder to the wall or your preferred location.

Use only the included erasers to remove and erase dry-erase markings. For a deep clean, we recommend using a non-alcohol based dry-erase board cleaner with a soft microfiber cloth.

Elite offers a replacement kit (**part number ZER3**) which includes:

- 1 x bottle of 8.45 oz cleaning solution
- 1 x microfiber cloth
- 2 x high density foam erasers
- 2 x sets of dry-erase markers (4 total)



Contact your reseller or visit [shop.elitescreens.com](http://shop.elitescreens.com) for pricing and purchase.

For more information, technical support or your local Elite Screens contact,

please visit [www.elitescreens.com](http://www.elitescreens.com)