



# Aeon CineGrey 3D®

*EDGE FREE® Ceiling Ambient Light Rejecting  
Fixed Frame Screen*  
**For Standard (long) throw Projectors**

## USER'S GUIDE – M Type

### Product Description:

The **Aeon CineGrey 3D® Series** is a fixed frame projection screen that uses Elite Screens' **EDGE FREE®** technology. The **EDGE FREE®** design resembles a giant size flat panel TV display. The **Aeon** includes a micro-thin bezel trim to further enhance the frame appearance.

The screen material included is our **ISF certified** CineGrey 3D, which is a reference quality front projection material precisely formulated for environments with minimal control over room lighting. It was designed to enhance picture brightness, offer accurate color fidelity, and improve contrast levels. The CineGrey 3D® is best for family rooms, educational facilities, conference rooms or any applications in which incident light is a factor.

In order for the CineGrey 3D projection surface to maintain its projection qualities and optimum performance, please refer to the list below for proper maintenance and cleaning.

- Use a dry microfiber cloth to remove dust from the screen's surface.
- When cleaning, use a damp microfiber cloth with warm water to remove any marks.
- Never rub or apply pressure when cleaning the surface.
- Never attempt to use any solutions, chemicals or abrasive cleaners on the screen surface.
- In order to avoid damaging the screen, avoid touching it directly with your fingers, pens/pencils or any other sharp or abrasive objects.

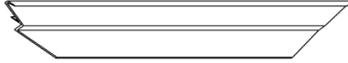
1. Frame and Edge Trim Parts List			
Qty item	2 pcs Main Frame Parts	Qty item	2 pcs Edge Trim Parts
Part A.	vertical frame 	Part D.	
Part B.	½ horizontal frame 	Part E.	
Part C.	½ horizontal frame 	Part F.	

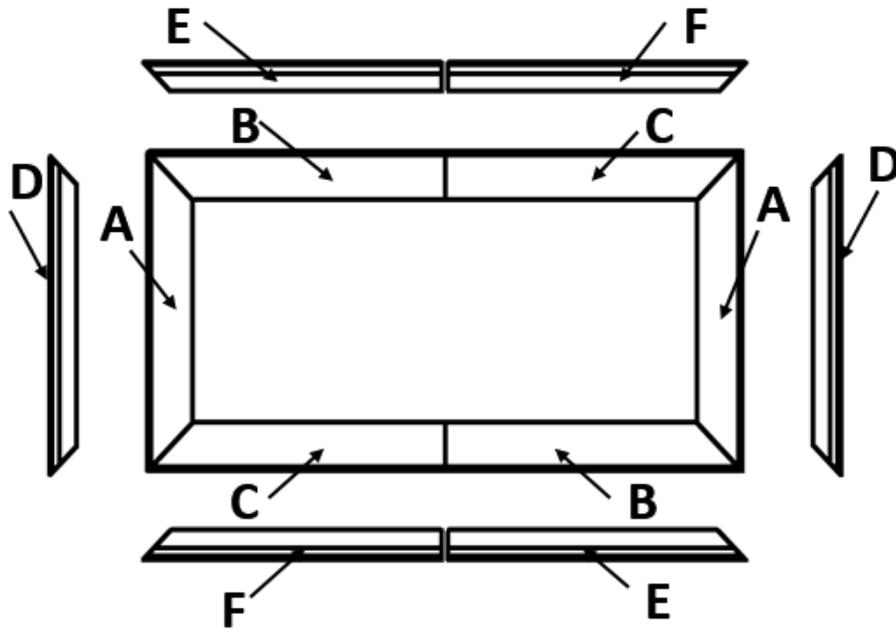

## 2. Hardware Parts List

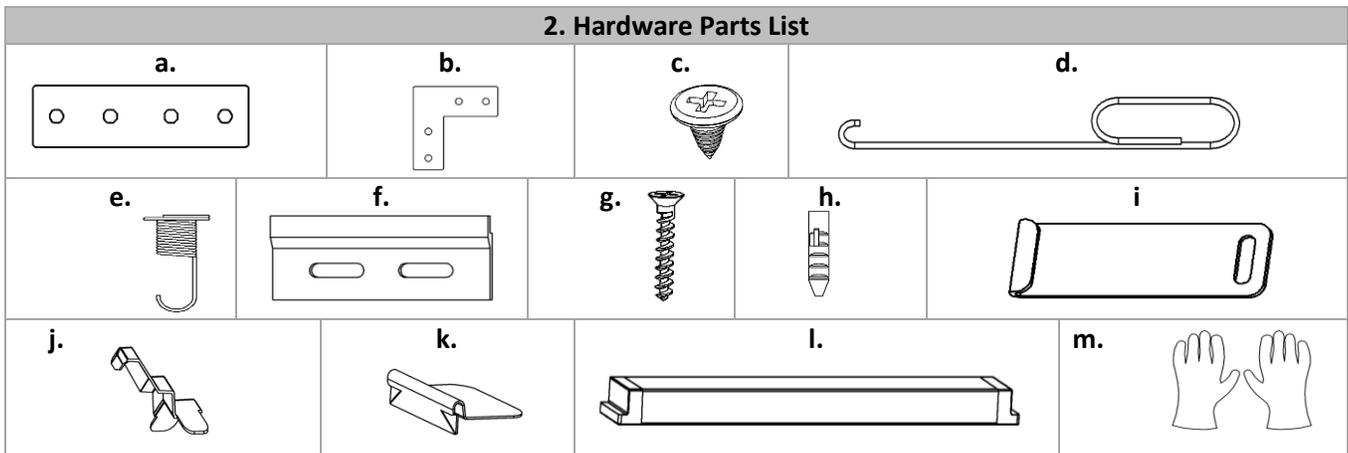

Item	Parts List	AR125C	AR138C	AR158C
a.	Center Joints (1)	4	4	4
b.	Elbow Joints (2)	8	8	8
c.	M4x6 Screws	60	60	60
d.	Spring Hook	2	2	2
e.	Spring	106	114	132
f.	Top wall brackets	2	2	2
g.	M5x50 Wall Screws	6	6	6
h.	Hollow Wall anchors	6	6	6
i.	Bottom wall brackets	2	2	2
j.	Angle cover	4	4	4
k.	LED light strip clip	8	8	8
l.	Center Support Bar	1	1	1
m.	White gloves	2	2	2

## Frame Assembly

**Step 1:** Place the soft padded EPE sponge on clean area on the ground where the screen will be assembled.

**Step 2:** Position the pieces of the frame on the EPE sponge in the arrangement shown below

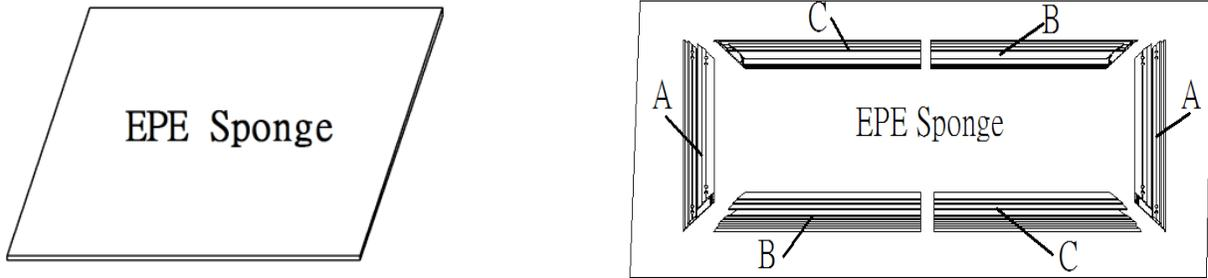

**Step 3:** Remove the tape on all frame ends before assembling the frame

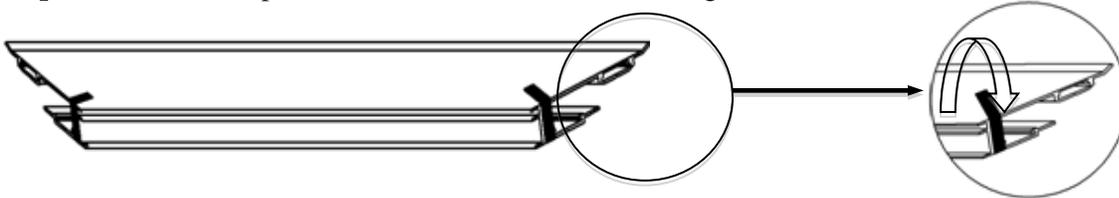

**Step 4:** Insert the *center joint (a)* connectors into *one-half of the horizontal frame (b/c)* and secure with the *M4x6 screws (c)*.

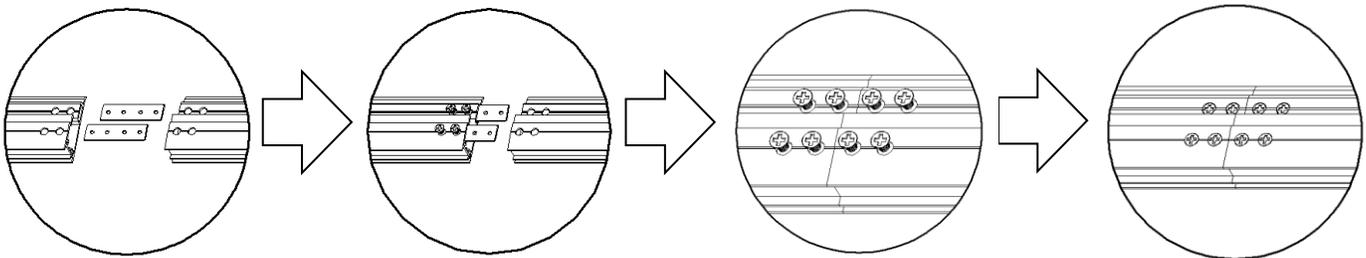

**Step 5:** Insert the *springs (e)* into the grooves of the frame. The spring's hooks should be facing the front side of the frame. For the correct amount of springs to place into the frame, please refer to the table listed below.

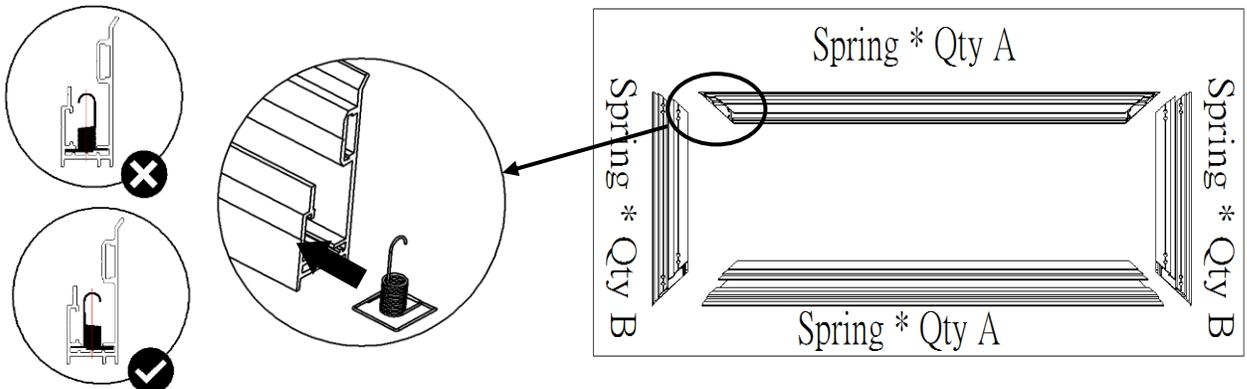

**Note:** The springs are pre-installed into the grooves of the frame.

Screen Size	125C	138C	158C	
Spring Qty	A	37	40	46
	B	16	17	20

**Step 6:** Connect the *elbow joints (b)* to the top and bottom sections of the vertical frame. Once inserted, connect the vertical sections of the horizontal frame sections. Make sure all holes are in alignment and the frame pieces are flush (no gaps). They should form perfect right angles.

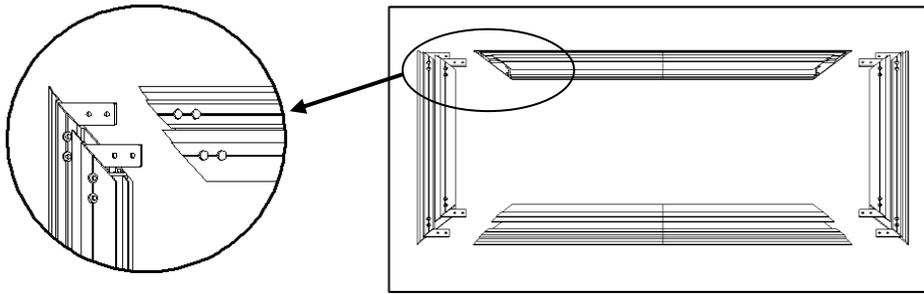

**Step 7:** Secure the elbow joints by fastening them with *M4x6 screws (c)*, 4 at each corner.

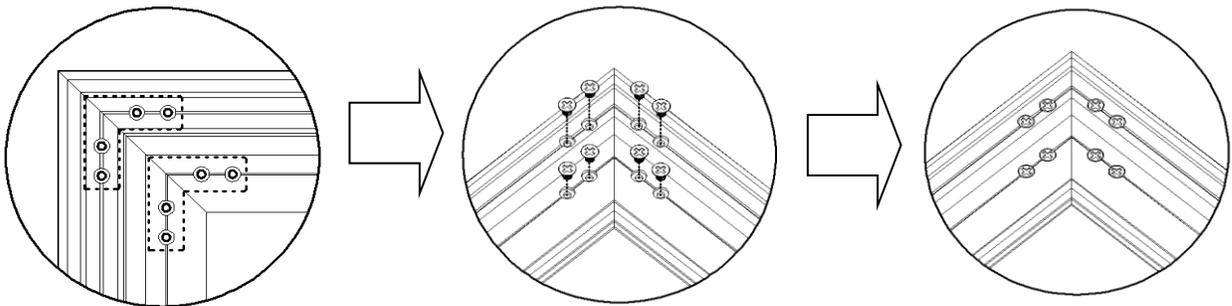

### Screen Material

**Step 8:** Put on the *white gloves (m)* and carefully unroll the screen material on a clean surface from the roller to the other side as shown below. The back side of the screen material should be placed upwards.

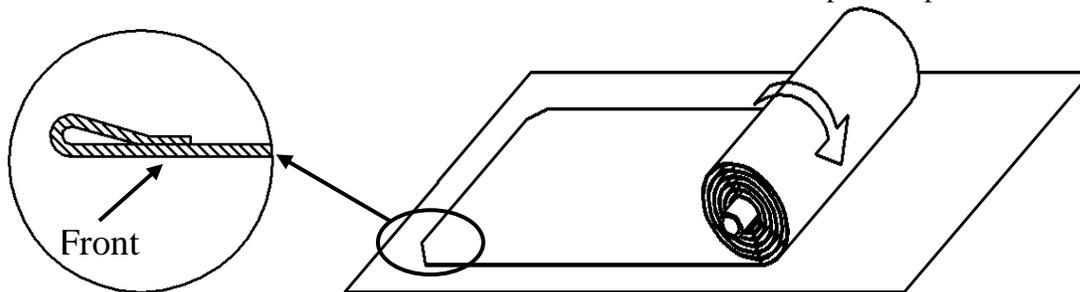

**Step 9:** Carefully and gently place the assembled frame on top of the screen material. Make sure to not allow the angle edge of the frame to come in direct contact with the screen material to avoid puncturing it.

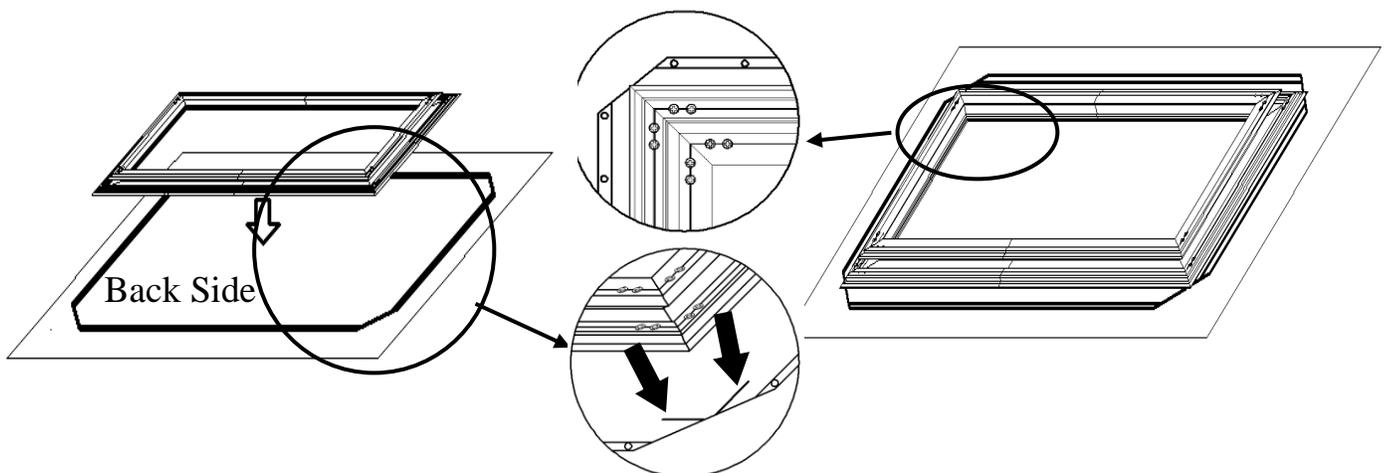

**Step 10:** With one end of the spring and secure inside the groove of the frame, use the *spring hook (d)* to attach the spring to the hole located on the screen material's outer edge in the following order.

Attach the four corners first (1). After those are secure, connect the vertical portions of the material, begin in the center and move towards the corners (2). Lastly, connect the horizontal sections of the material by connecting the center of the material and make your way towards the corners (3).

**Note (after all springs have been attached):**

**Correct material installation** –Corners of the screen material are properly wrapped around the corner edges of the frame and material is evenly tensioned and flat, creating a nicely taut surface.

**Incorrect material installation** –The corners of the screen material are not properly wrapped along the edge of the frame leaving the material with unbalanced tension and an uneven finish. To correct, detach springs from material at the corner(s) where material does not lie flat along the edge of the frame, reposition the material so that it lies flat and wraps along the edge of the frame, and reattach springs to the material.

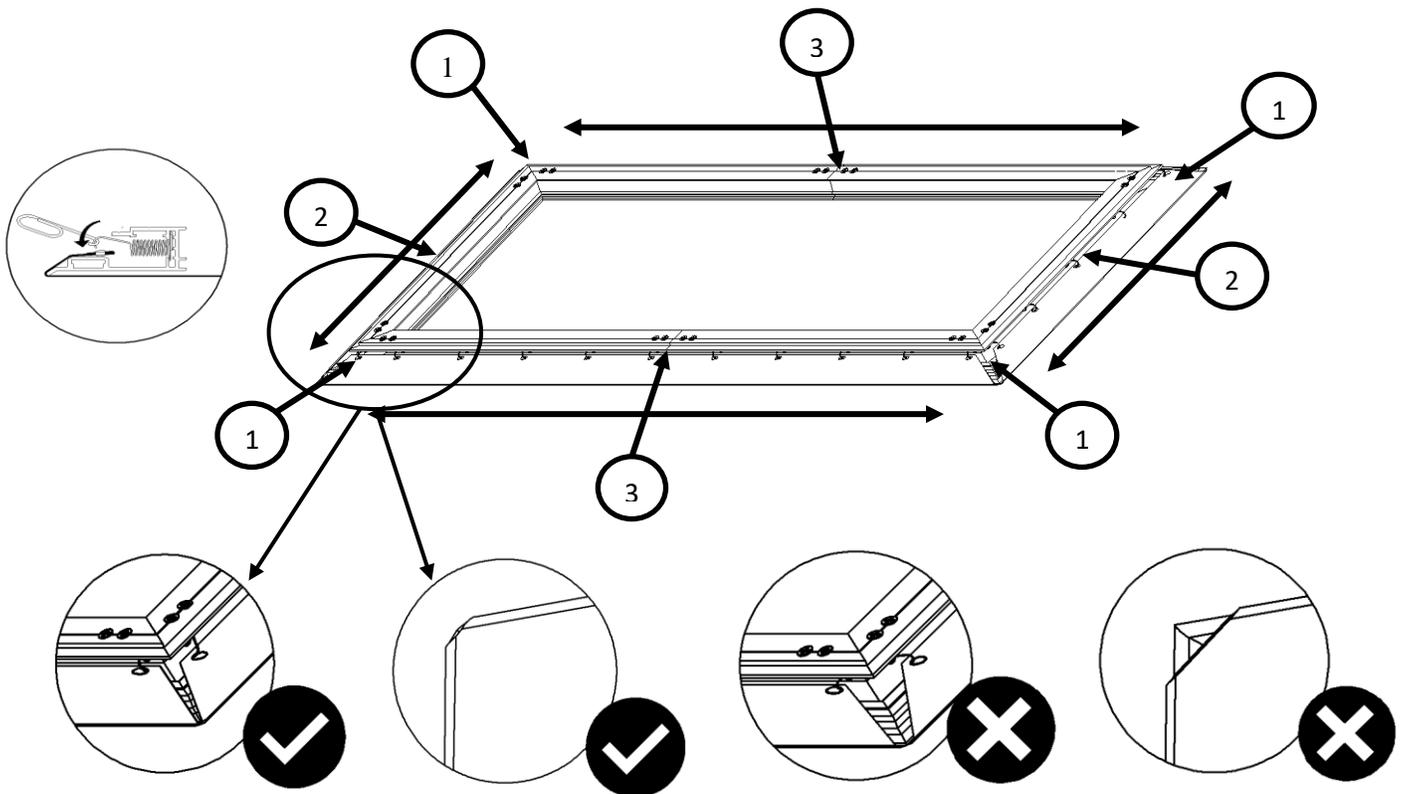

*To avoid ripples forming in the material it is imperative that all of the corners are properly wrapped around the edges as illustrated in the check mark diagrams.*

## Center Support Bar

**Step 11:** Insert the *Center Support Bar (i)* into the upper top groove on the back of the frame with the bottom end near the approximate center point of the frame and rotate it in at an angle so that both ends of the bar are in alignment with the groove.

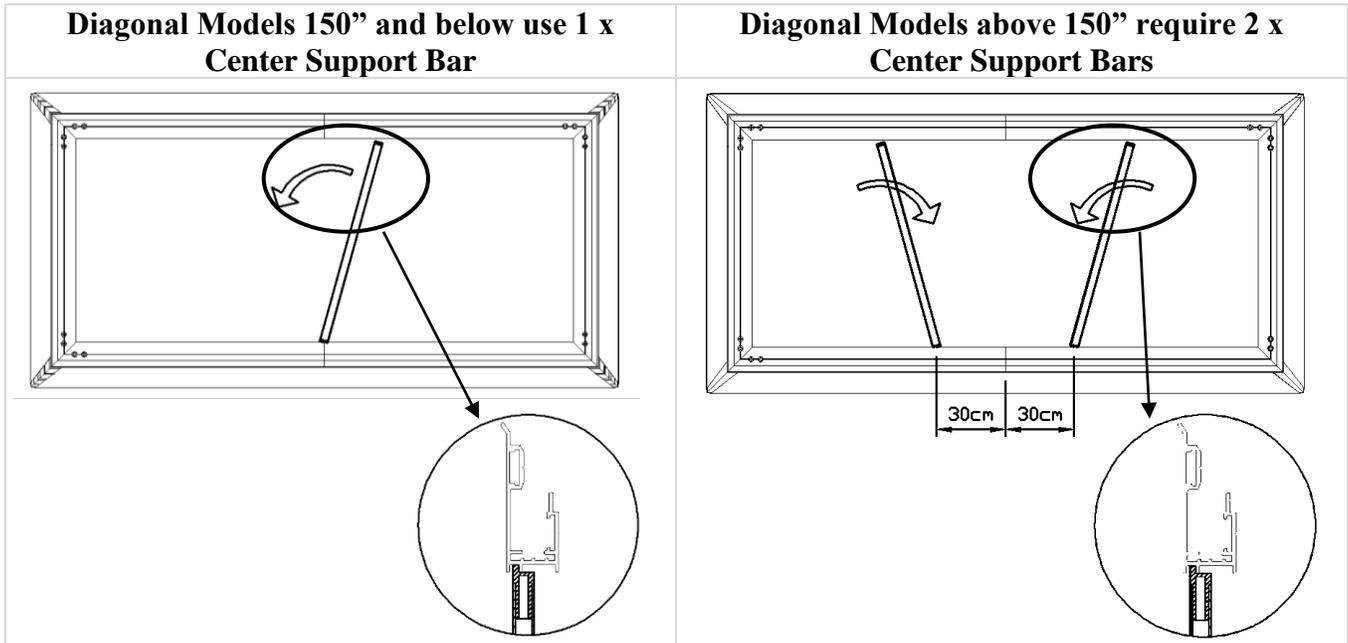

**Attention:** Do not proceed with the Edge Trim installation until making sure there are no ripples in the material.

### How to avoid getting ripples on the screen's material surface

**Solution:** Pull and smooth out the material using your hand from the center to the corners, creating a nicely taut surface as shown below.

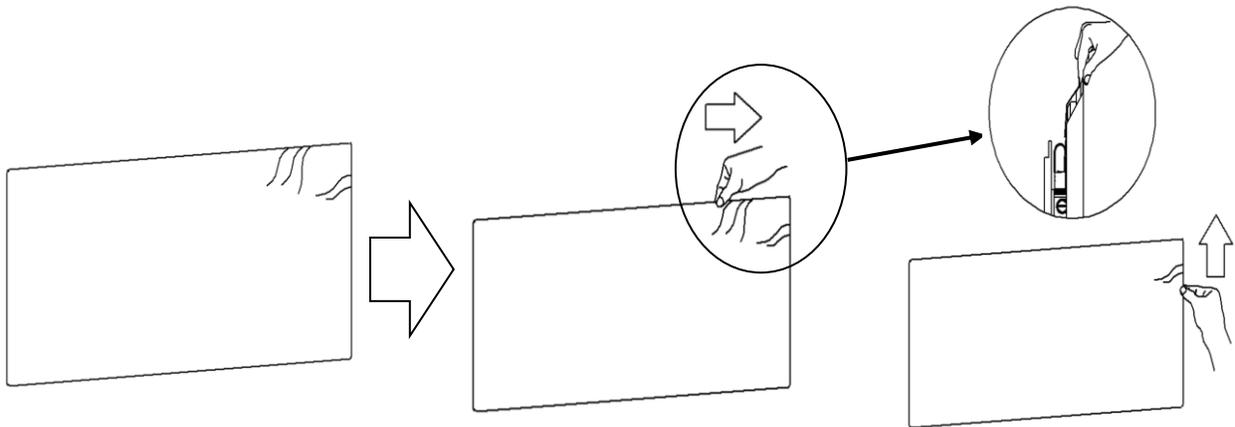

## Edge Trim Installation

**Step 12:** Place the *Edge Trim* over each end of the frame and secure with *M4x6screws (c)*. Start with the center points first, then the rest of the corners as shown below.

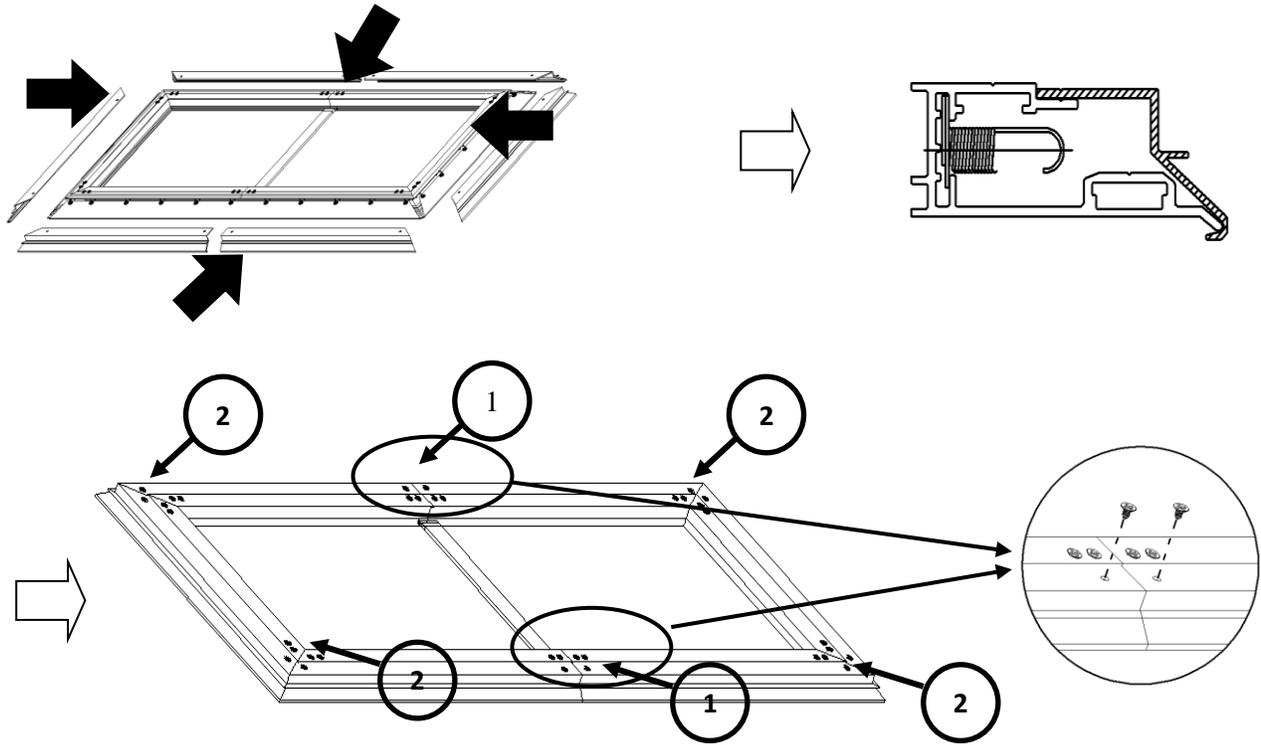

**Step 13:** Install the *angle cover (j)* on each corner of the frame and install the LED light strip to hold down the angle cover.

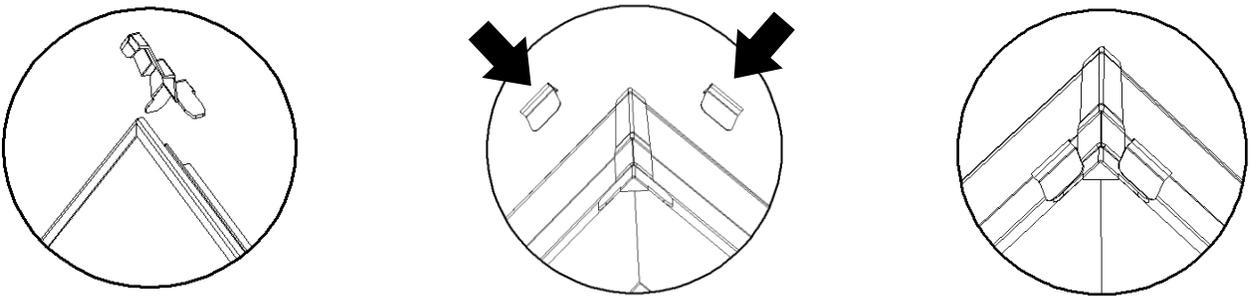

## Notice to Installer:

Please use the following installation instructions to obtain superior optical performance from the CineGrey 3D Angular Reflective ALR (Ambient Light Rejecting) Screen.

- Angular-Reflective material is not compatible with ultra/short-throw projectors
- Minimum lens throw ratio 1.5x image width
- Ambient light must not come from the same direction as the projector

*Since angular-reflective means that the projected image will reflect at the mirror-opposite angle, it is important to position the projector so that the viewer will get the best possible image.*

**Step 1:** Establish the general “eye level” of the viewers

**Step 2:** Set the appropriate projection level

**Step 3:** Adjust the screen height level and projection angle

Input Angle (A) = Output Angle (B) aligns with the viewer’s angle

### Correct Installation Examples

**Projector Ceiling Installation:** Make sure the projector (*light in*) is angled (A) to reflect (B) at the mirror-opposite angle (*light out*) to align with the viewer’s eye level.

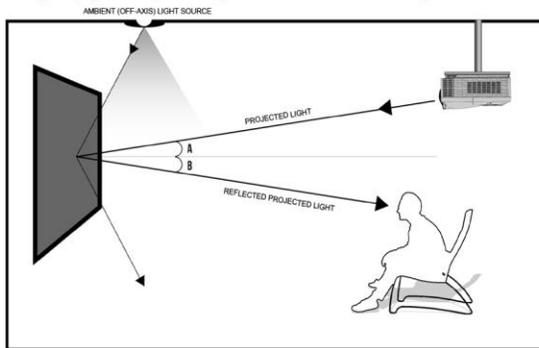

PROJECTOR CEILING INSTALLATION

**Projector Table Top:** Make sure the projector (*light in*) is angled (A) to reflect (B) at the mirror-opposite angle (*light out*) to align with the viewer’s eye level.

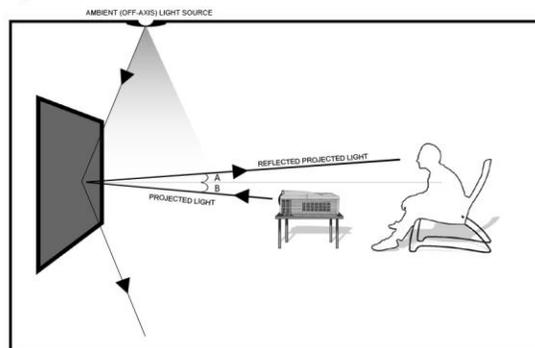

PROJECTOR TABLE TOP INSTALLATION

### Incorrect Installation Examples

**Ceiling Mounted Short-throw Projector**

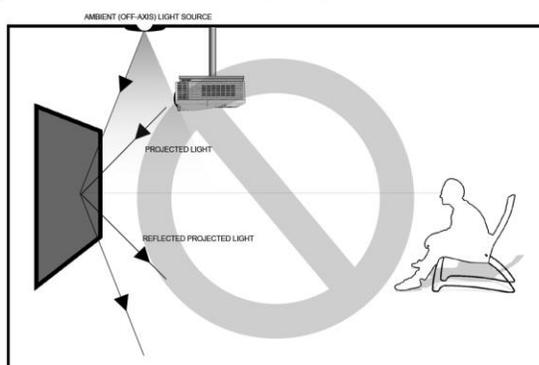

CLOSE UP CEILING PROJECTOR ILLUSTRATION (NOT COMPATIBLE)

**Tabletop Ultra-Short throw Projector**

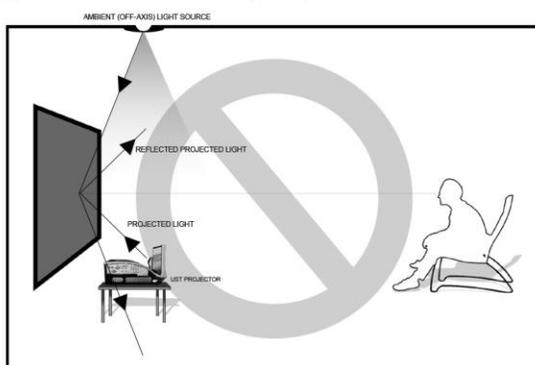

ULTRA SHORT THROW PROJECTOR ILLUSTRATION (NOT COMPATIBLE)

**Note:** Improper installation will result in light loss and produce a dark image. This is due to the projector’s light reflecting in the wrong direction.

Images are not up to scale and are for illustration purposes only.

## Wall Installation

**Step 14:** Measure the overall length and height of the frame and drill holes for the top brackets. Line up the wall brackets with the drilled holes on the installation location and screw them in using a Phillips screwdriver. If not installing into a structural wood stud, use a hollow wall anchor then screw in the M5x50 wood screws with a screwdriver. Make sure the brackets are leveled.

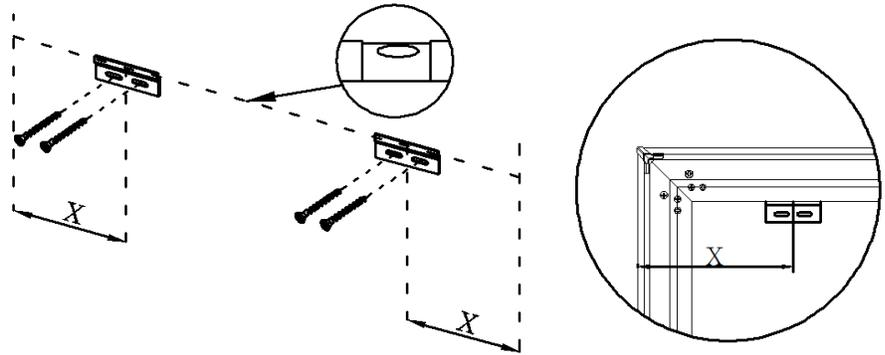

**Step 15:** Position the fixed frame screen onto the top wall brackets as shown below and push down at the center of the top of the frame to secure.

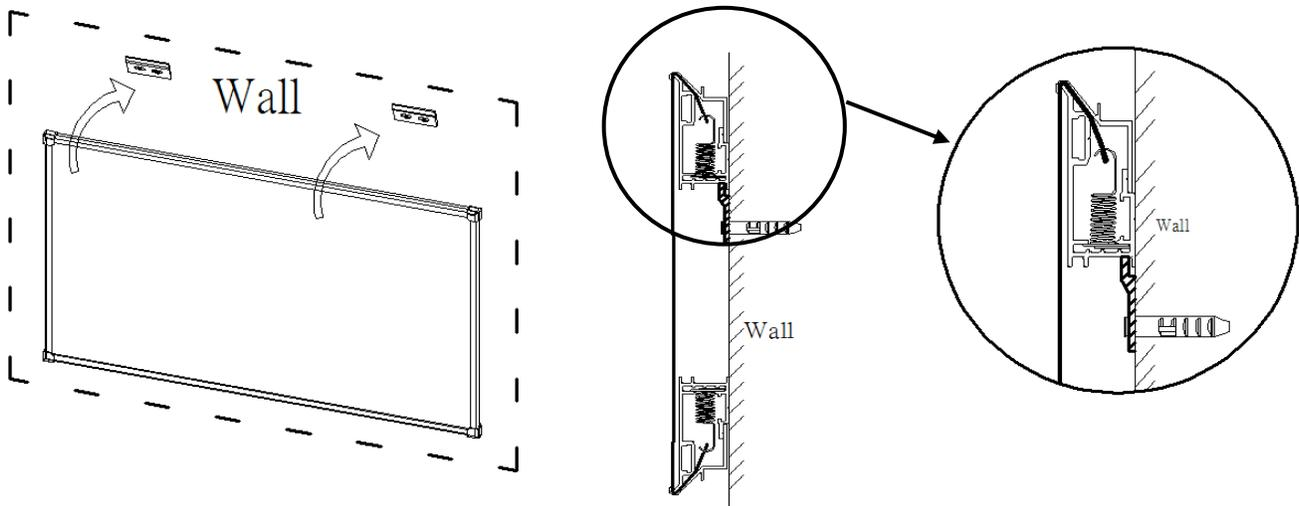

**Step 16:** With the frame slightly tilted outward; connect the bottom brackets onto the bottom groove of the frame. Then secure them by screwing onto the wall.

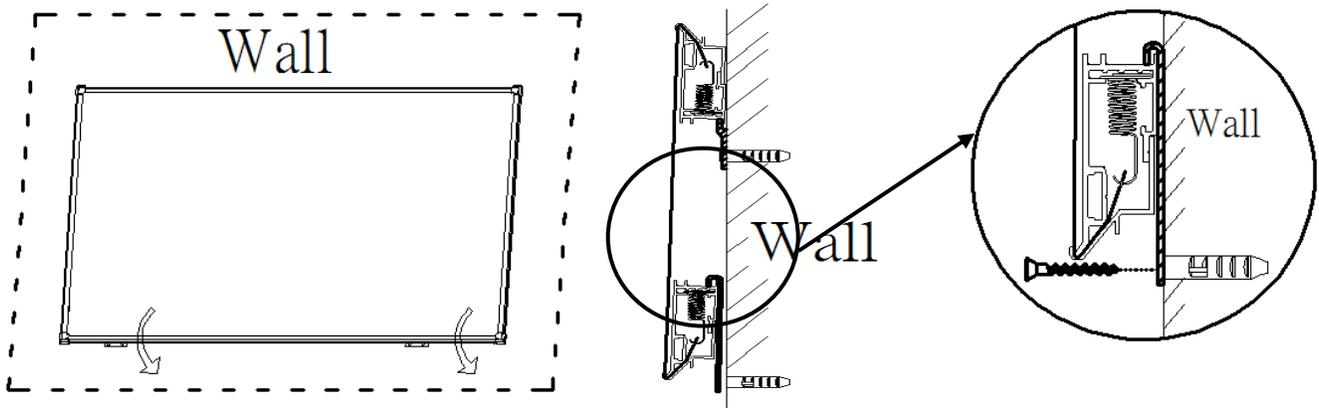

**For Technical Support or an Elite Screens contact in your area, visit**

[www.elitecreens.com](http://www.elitecreens.com)