

Manual Tab-Tension 2 Dimensions Table - M Type

Model Number	Nominal Diagonal	Aspect Ratio	Viewable Width (A)	Case Length (A1)	Screen Width (A2)	Weight Bar Length (A3)	Border Width (A4)	Viewable Height (B)	Screen Height (B1)	Top Border (B2)	Bottom Border (B3)	Overall Height (B4)	Handle (B5)	Case Width (C1)	Case Height (C2)	Packing Dimensions (LxWxH)	Net Weight	Gross Weight
Unit: inch																	Lbs	Lbs
MT106XWH2	106	16:9	92.4	107.6	97.6	106.4	1.4	52.0	68.5	12.0	2.6	95.3	1.8	4.4	4.1	115.0x8.3x7.7	27.4	34.4
MT125XWH2	125	16:9	108.9	124.7	115.0	123.5	1.4	61.3	77.8	12.0	2.6	100.1	1.8	4.4	4.1	131.9x8.3x7.7	31.3	39.6
MT140XWH2	140	16:9	122.0	137.2	127.3	136.0	1.4	68.6	85.2	12.0	2.6	110.5	1.8	4.4	4.1	144.5x8.3x7.7	35.4	44.6
Unit: mm																	Kgs	Kgs
MT106XWH2	2692	16:9	2346	2732	2480	2702	35	1320	1740	305	65	2421	46.2	111	105	45.3x3.3x3.0	12.5	15.7
MT125XWH2	3175	16:9	2767	3168	2920.5	3138	35	1556	1976	305	65	2542	46.2	111	105	51.9x3.3x3.0	14.2	18.0
MT140XWH2	3556	16:9	3100	3484	3233.5	3454	35	1743	2163	305	65	2807	46.2	111	105	56.9x3.3x3.0	16.1	20.3

Note: Data Error ±1"

The listed measurements are for general reference only. Please contact Elite Screens to verify product design and dimensions before attempting to integrate its products with any structural or furniture modification. Although a manufacturer may offer product advice, it may be taken or disregarded at the integrator's discretion. Elite Screens will not be held responsible or be otherwise liable for faulty installations

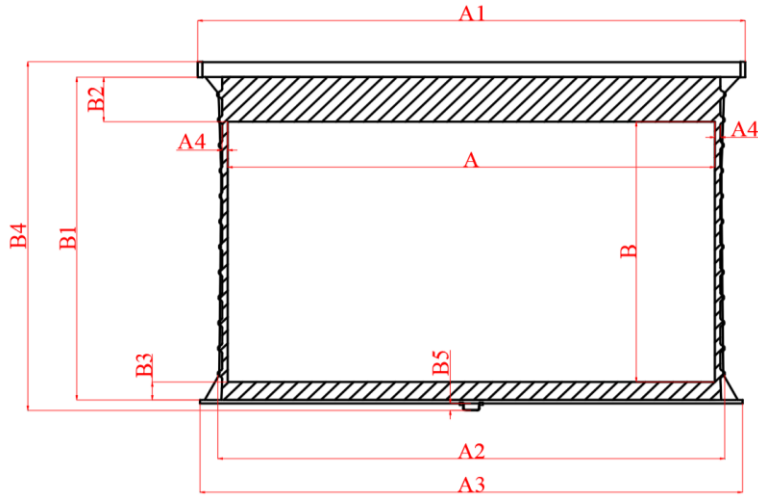

Wall/Ceiling Installation Bracket Dims

