

Spectrum Tab-Tension 2 Dimensions Table (Z Type)

Model Numbers	Diag. Size	Aspect Ratio	View Width (A1)	View Height (A2)	Screen Width (B1)	Screen Height (B2)	Case Height (B3)	Case Width (B4)	Overall Case Length (C1)	Weight Bar Length (C2)	Overall Height (C3)	L/R Borders (D1)	Bottom Border (D2)	Top Border (D3)	Power Cord Length (E5)
Unit: Inch															
Electric100HT	100"	16:9	87.0	48.8	89.4	61.8	3.3	3.3	107.9	98.4	66.3	1.2	1.2	11.8	63.0
Electric125HT	125"	16:9	109.1	61.4	111.4	74.4	4.1	3.9	129.9	123.4	79.7	1.2	1.2	11.8	63.0
Unit: mm															
Electric100HT	100"	16:9	2210	1240	2270	1570	85	85	2740	2500	1685	30	30	300	1600
Electric125HT	125"	16:9	2770	1560	2830	1890	105	100	3300	3135	2025	30	30	300	1600

Note: Data Error ±1"

The listed measurements are for general reference only. Please contact Elite Screens to verify product design and dimensions before attempting to integrate its products with any structural or furniture modification. Although a manufacturer may offer product advice, it may be taken or disregarded at the integrator's discretion. Elite Screens will not be held responsible or be otherwise liable for faulty installations

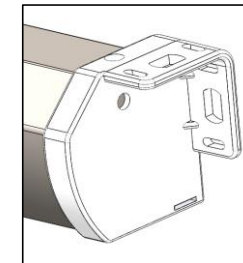
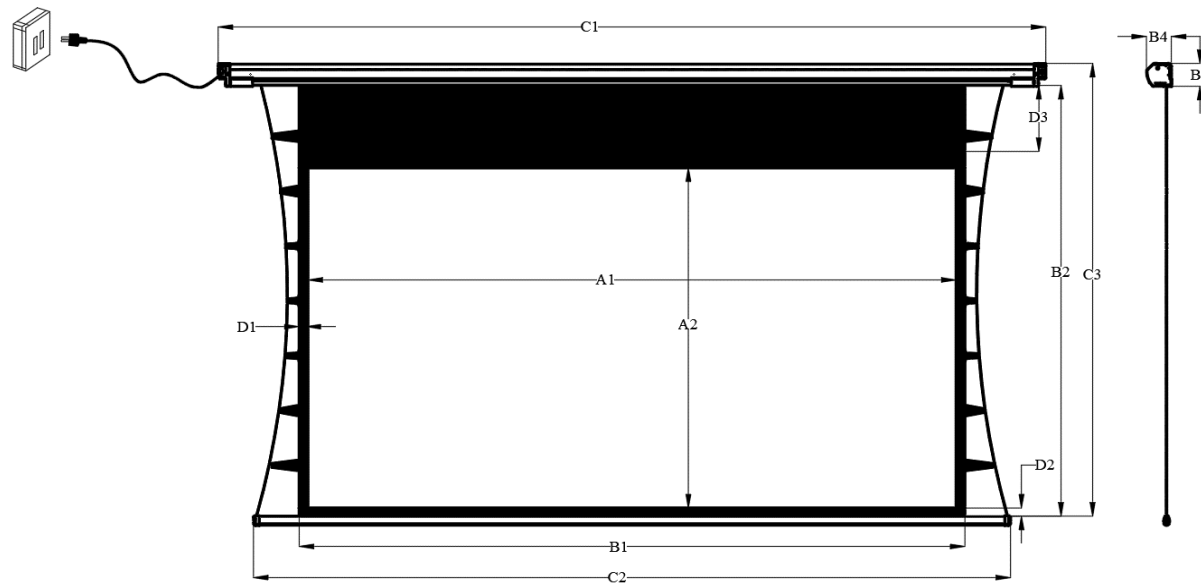

Case for Below 125" Models

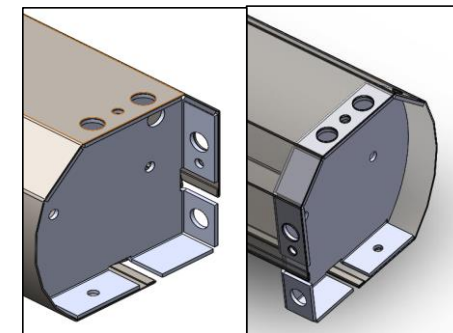

Case for 125" Models and Above