

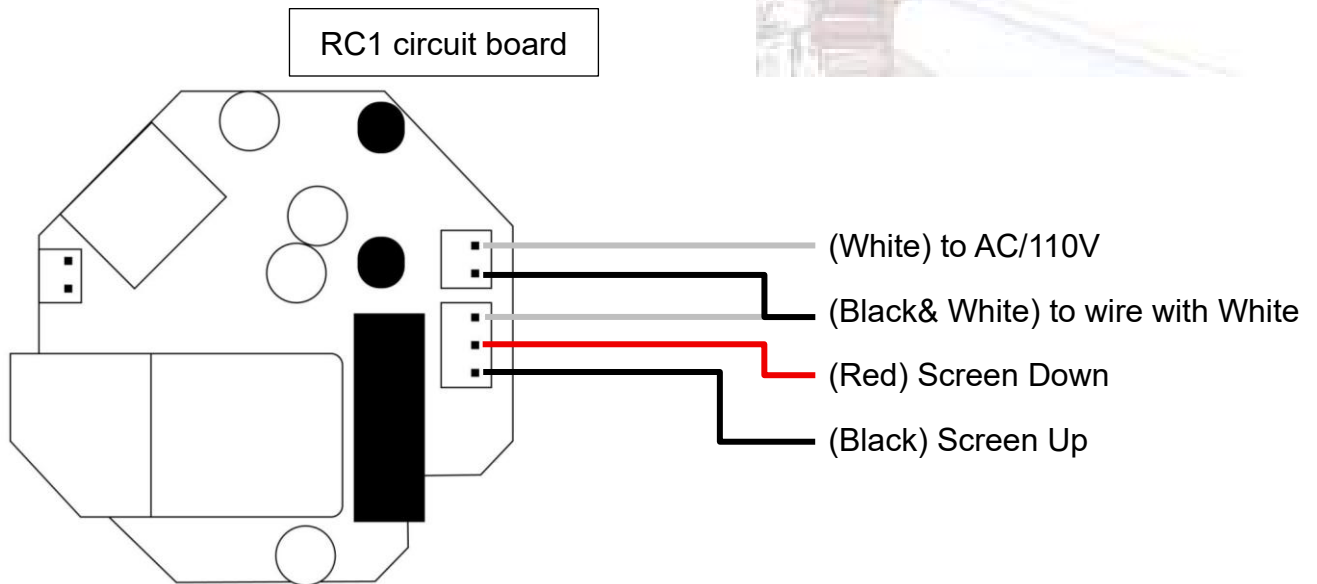

Dry Contact Connection (Direct Control)

Open your motorized screen left end cap to see following circuit board, 3PIN & 2PIN connectors and follow the steps to modify to new dry contact connection to your control system.



- Step 1: Open Motorized Screen Left End Cap (as you face the front of the screen)
- Step 2: Unplug the connector of 3-pin & 2-pin cable
- Step 3: Wire 3 pin/White wire & 2 pin/Black wire together
- Step 4: 2 pin/White Wire is for AC/110V
- Step 5: 3 pin/Red is for Screen Down Wire
- Step 6: 3 pin/Black is for Screen UP Wire

Wire 12V trigger connection below

