



Light-On CLR® 3 Series
Tripod Tab-Tension model # TT55V-CLR3
Indoor Ceiling Ambient Light Rejecting Portable Screen
For tabletop mounted ultra/short-throw projectors
User's Guide – Z Type

Thank you for choosing the **Light-On CLR® 3** Tripod Tab-Tension model. This product is a portable tripod projection screen with ceiling ambient light rejecting technology for portable projector presentations on the go.

The screen material included is our **CLR® 3**, which is an optical lens front projection material precisely formulated for environments with minimal control over room lighting. It was designed to filter and absorb overhead light while directing tabletop mounted projectors. It best for family rooms, educational facilities, conference rooms or any applications in which incident light is a factor.

CAUTION!

THE PROJECTION FABRIC IS A DELICATE OPTICAL/LENTICULAR SCREEN MATERIAL AND SHOULD NOT BE FOLDED, BENT, OR CREASED. ALWAYS MAINTAIN SCREEN MATERIAL FLAT AND TAUT DURING SETUP AND DISASSEMBLY. IT IS VERY IMPORTANT ALL INSTRUCTIONS ARE FOLLOWED TO AVOID DAMAGING THE MATERIAL. ANY DAMAGES RESULTING FROM NEGLIGENCE OR MISHANDLING WILL VOID YOUR WARRANTY.

Screen maintenance

Dust, dirt, and scratches on the projection screen surface will affect the quality and performance of the projection image. Follow the instructions below to properly maintain the screen.

- 1) The screen surface has a horizontal linear structure. **DO NOT** wipe the screen up and down or in a circular motion. **Wipe gently from left to right only.**
- 2) Clean the dust on the screen surface with a soft brush or microfiber cloth. A rough/coarse towel or cloth may damage the screen's surface.
- 3) Gently wipe the screen with a lightly moistened white lint free cloth with water or with a neutral detergent (1mL/0.33 oz) mixed with water (1000 mL/33.8 oz).
- 4) Avoid putting pressure on the screen material when wiping the screen. If dust or other debris is on the surface, we recommend using an air sprayer to blow them away.

Notes: *The following precautions should always be followed to avoid damaging the material, which is not covered under warranty.*

- Don't touch the screen material to avoid leaving fingerprints.
- Use gloves when handling the material.
- Don't scratch the material, as it will leave permanent markings on the screen's surface.
- Don't point to the screen material with a fingertip or other sharp objects to prevent damage to the material.
- Don't use acetone, benzene, alcohol and any other organic solvents to clean the screen material. Using such chemicals will permanently damage the screen.

Tripod Screen Parts Identification

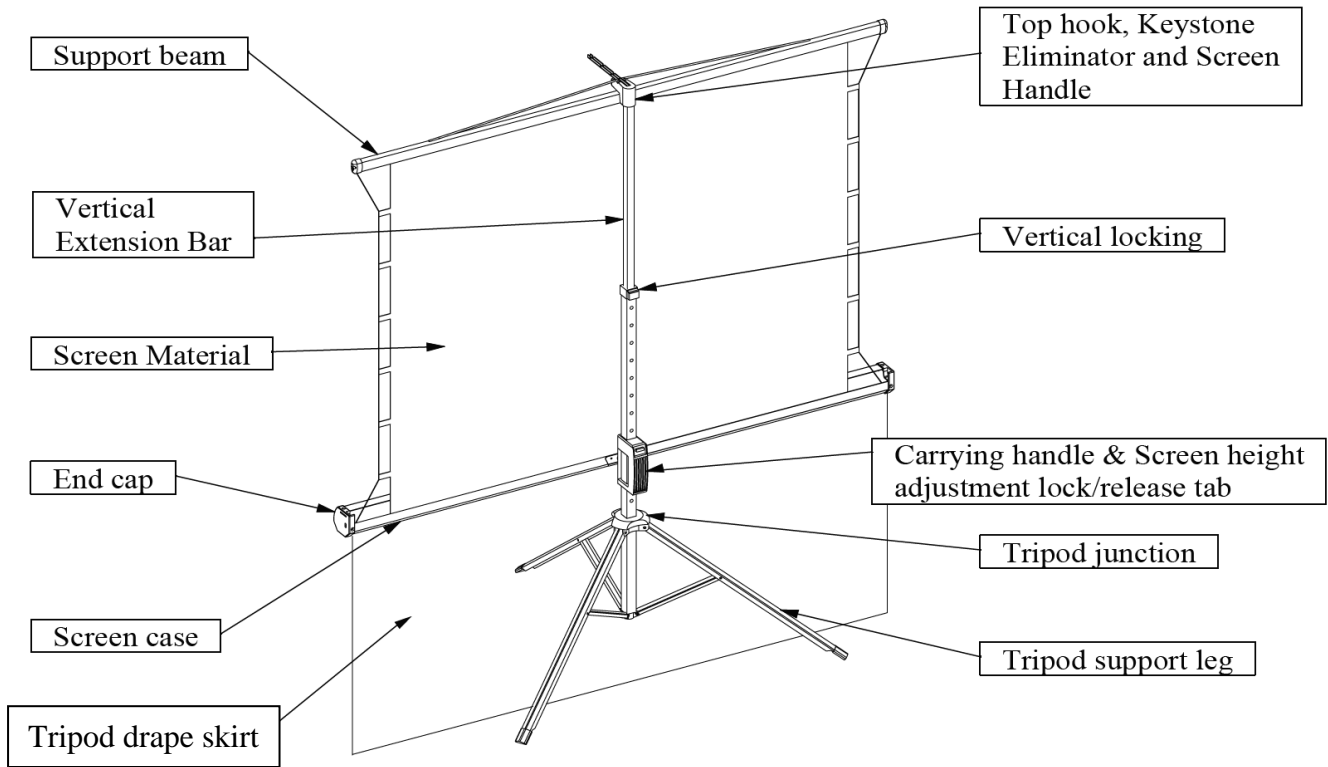

A. Tripod Screen Setup

Follow the steps below and Fig. 1 & 2.

1. Place the screen in an upright position (Fig.1) with the legs toward the ground.
2. Deploy the Tripod **Support legs** by pushing down on the **Tripod Junction**.
3. Turn the tripod's screen case in a 90-degree horizontal position so that the screen casing is now parallel to the ground with the screen handle facing the bottom of the top hook.
4. Completely extend the legs as much as possible so they are stable and position them away from objects that may interfere with their balance. **DO NOT** stand the tripod on an unstable platform to avoid an injury should the tripod screen collapse.

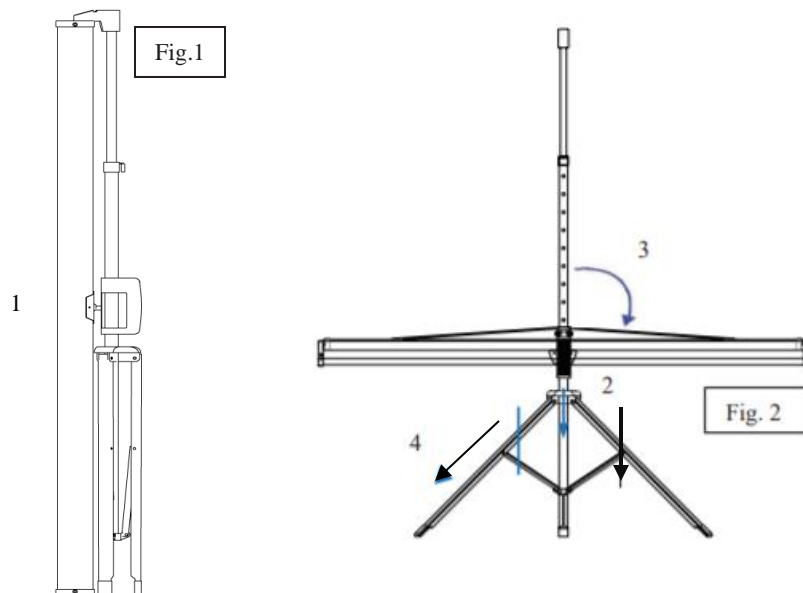

B. Preparing the tripod screen for projection:

Follow the steps below and Fig. 3.

1. Pull the screen handle up vertically and hook the screen handle on the **Top Hook**.

NEVER PULL THE SCREEN MATERIAL TO RAISE IT.

Note: Use the Keystone Eliminator to prevent “Keystone Effect” from occurring. Keystone Effect is caused when a projector presents its image at a downward angle causing a trapezoid-shaped image to appear on the screen. The Keystone Eliminator is designed to eliminate that effect by sloping the screen forward.

2. Push/press the **Vertical Locking Tab** to unlock the current position of the **Vertical Extension Bar** and raise it with another hand. Remain pushing on the button until you reach the desired height and let go until you hear a click sound which indicates it is locked in place.

3. Push/press the **Screen Height Adjustment Lock/Release** located just above the **Carrying Handle** to raise or lower the bottom of the screen. Once the desired height has been set, let go of the tab to lock the position in place.

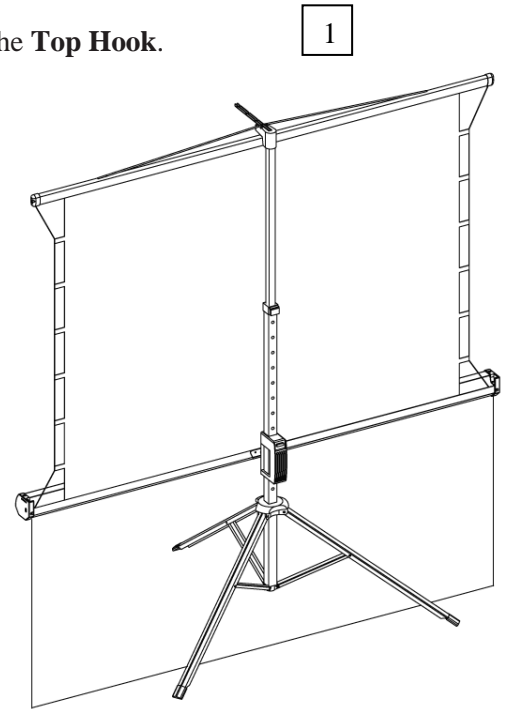

C. Tripod Skirt Installation

4. Unfold the tripod skirt in a clean area. Use the magnetic bars to attach it to the tripod case.

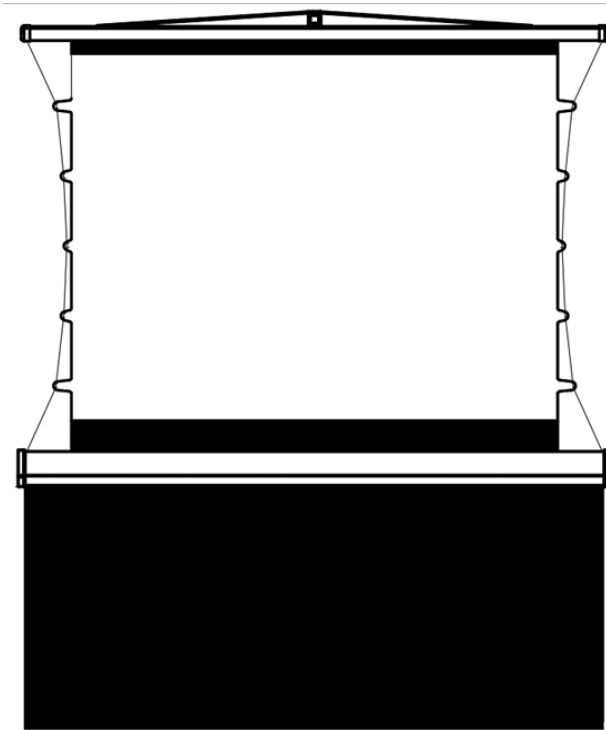

Notice to Installer:

PROPER PROJECTOR PLACEMENT

The CLR[®] 3 is exclusively for tabletop mounted ultra-short throw projectors.
See illustrations for limits and criteria.

1) Tabletop mounted Ultra-short throw projection illustration

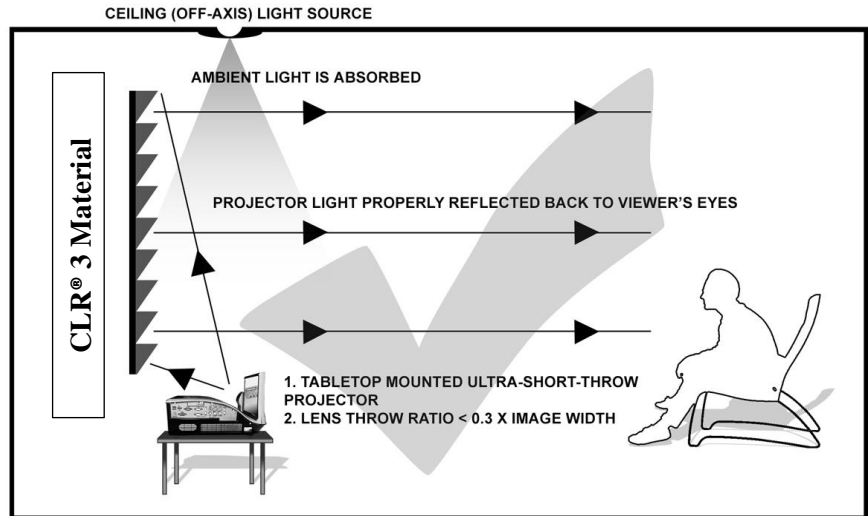

IMPROPER PROJECTOR PLACEMENT

Overhead placement or a standard projector will make the image very dark, on account of the screen's absorbent layer deflecting light that is not aligned with its reflective angle.

1) Ceiling Mounted Ultra-Short Throw Projector Illustration

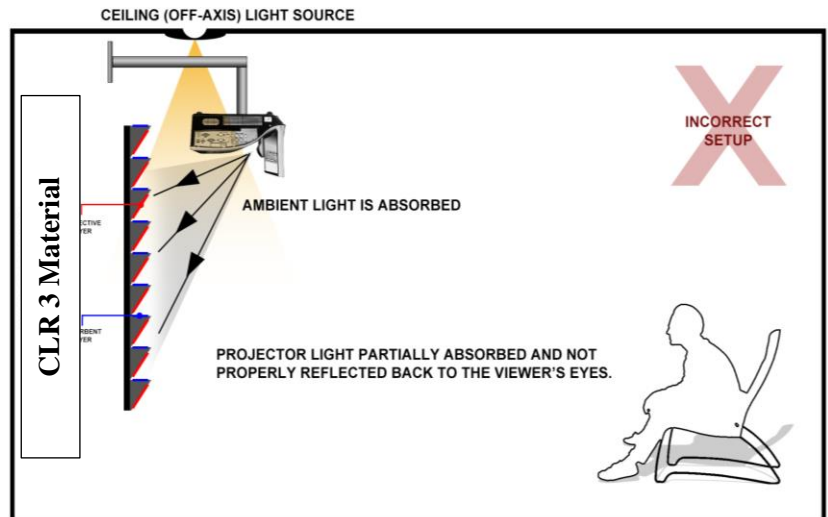

2) Ceiling Mounted Short and Standard-Throw Projector Illustration

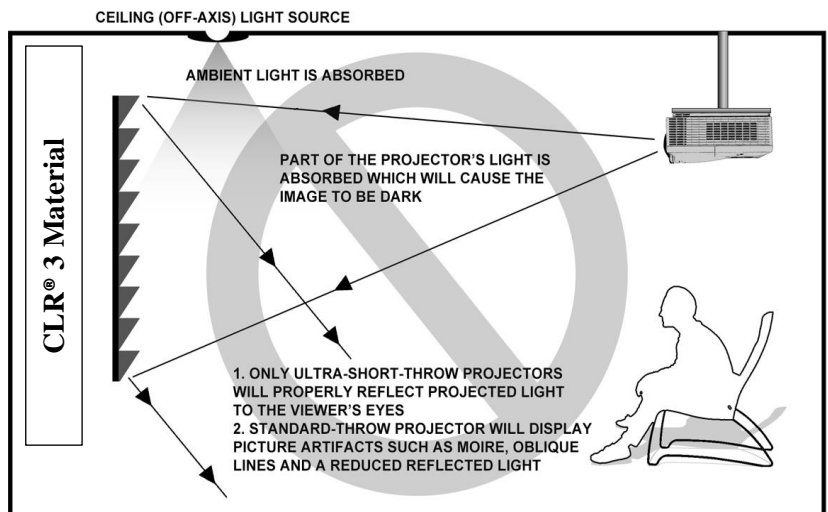

B. Collapsing the screen:

Follow the steps below and Fig. 4.

1. Push/press the **Screen Height Adjustment Lock/Release** to unlock and slowly slide the handle all the way up to slowly retract the screen into its case.
2. Unhook the screen material from the **Top Hook** and slowly retract the screen back into the case.
3. Once the material is in its case, Push/press the **Screen Height Adjustment Lock/Release** to unlock and slowly slide the handle all the way down to bring down the position of the screen's case.
4. Hold the **Extension Bar** and Push/press the **Vertical Locking tab** to unlock and release the position of the extension bar. Bring the extension bar all the way down.

Note: It is very important to remember to hold the extension bar first and then unlock the adjustment tab to prevent the extension bar from slamming and causing injury or damaging the screen.

5. Turn the screen's case **vertically clockwise** and insert the **TopHook's** bottom pin to lock into the screen's end cap hole.
6. Close the tripod legs by pushing them in.

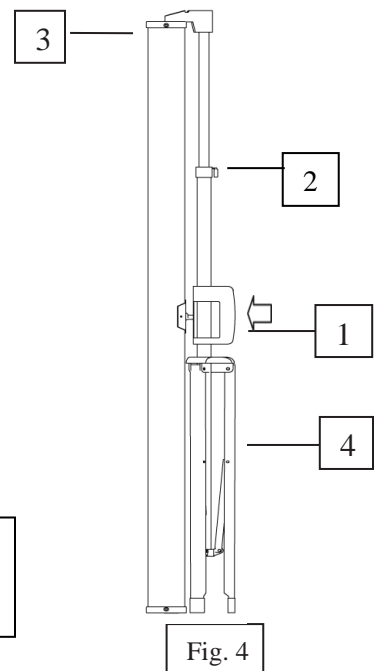

Note:

- To ensure the screen is stable, extend the tripod's legs as much as possible.
- Do not fold the screen or allow any sharp objects to touch the screen's surface.
- Clean the screen surface often when needed.
- Careful use will extend the lifetime of this product.

For more information, technical support or your local Elite Screens contact, please visit www.elitescreens.com