



Yard Master Awning Series

Free Standing Shade and Outdoor Projection Screen



Owner's Manual

For safety reasons, please read the instructions and warnings in this manual carefully before installing the awning.

Assembly Video

Watch our assembly video on-line at www.elitescreens.com/ym_awning_video or scan the QR code

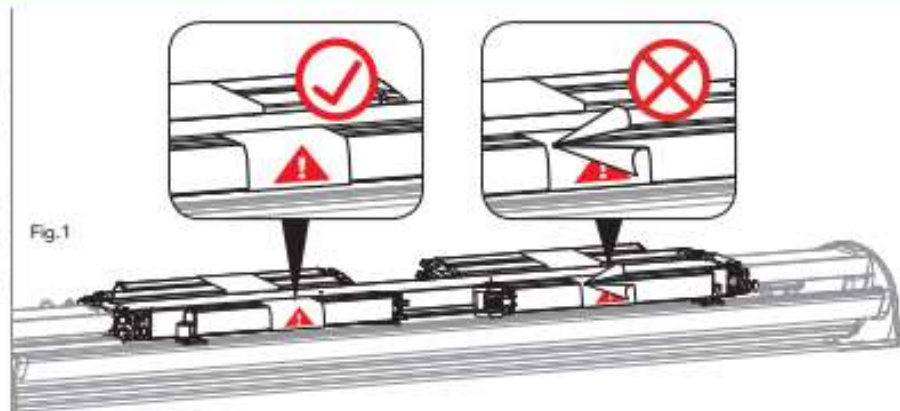

TABLE OF CONTENTS

Safety instructions and warnings.....	2
Package contents and parts.....	3
Tool requirements.....	4
Product Features.....	5
Assembly	
Determine where to place your awning	6
Assemble the awning support structure	6
Secure the awning to support structure	7
Secure awning to ground	8
Operation	
Ready your awning	9
Operate your awning	9
Projection Screen installation/removal	10
Maintenance	10
Warranty	11

SAFETY INSTRUCTIONS

In order to avoid accidental injury or product damage, **DO NOT** remove the safety restraints from the awning's lateral arms until instructed to do so.



SAFETY INSTRUCTIONS AND WARNINGS

TO REDUCE THE RISK OF FIRE, ELECTRIC SHOCK, OR INJURY

- Pay close attention during assembly to ensure that the Advaning awning is assembled properly.
- Perform the assembly in dry and optimal conditions. Always wear protective gear and gloves when handling sharp metal parts. If you do not feel that you can properly assemble the awning, please seek professional help.
- The Advaning awning should only be operated by an adult that understands all the functions and operations of the awning. Please keep unsupervised children away from playing with the awning or its parts.
- The product should be used only as described in this Advaning Owner's manual. Do not carry out any maintenance other than what is shown in this manual. For any issues that are not covered in this manual, please seek support from Advaning Customer Service.
- Only use Advaning recommended accessories and original replacement parts.
- Do not place any heat source or open flame under or near the awning.
- Do not place, hang, or stand persons on the awning itself, doing so can damage the awning or cause severe personal injury and in extreme cases death.
- Do not place, hang, or stand objects not specified by Advaning or weights more than 18lbs, on the awning. Doing so can damage the awning or cause severe personal injury and in extreme cases death.

For safety reasons we strongly recommend the following during installation:

- A: Minimum 2 people
- B: Work gloves
- C: Safty goggles

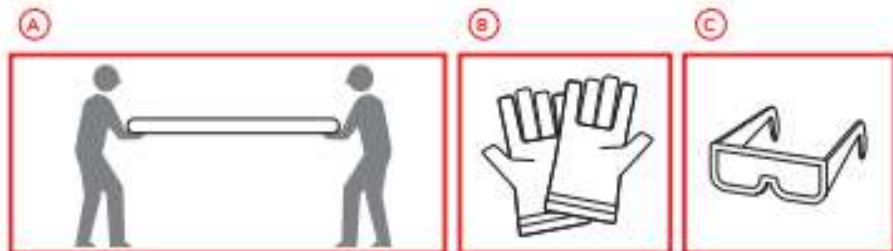

Fig.2

DO NOT keep the awning open during:

- D: RAIN
- E: SNOW
- F: STRONG WIND
- G: AWAY FROM HOUSE



Fig.3

PACKAGE CONTENTS AND PARTS

Before installation, make certain that the package contains all parts as listed on this page.

- ① Awning Module (1)
- ② Hand Crank (1)
- ③ Upright Leg Cover (2)
- ④ Upright Leg (2)
- ⑤ Lower Leg Top Cover (2)
- ⑥ Lower Leg Bottom Cover (2)
- ⑦ Lower Leg (2)
- ⑧ Supporting Brace (2)
- ⑨ Short Base (2)
- ⑩ Long Base (2)
- ⑪ M8x90 Upright Leg Bolt Set (4)
- ⑫ Lower Leg Screw and Washer Set (8)
- ⑬ M6x16 Supporting Brace Screw and Washer Set (8)

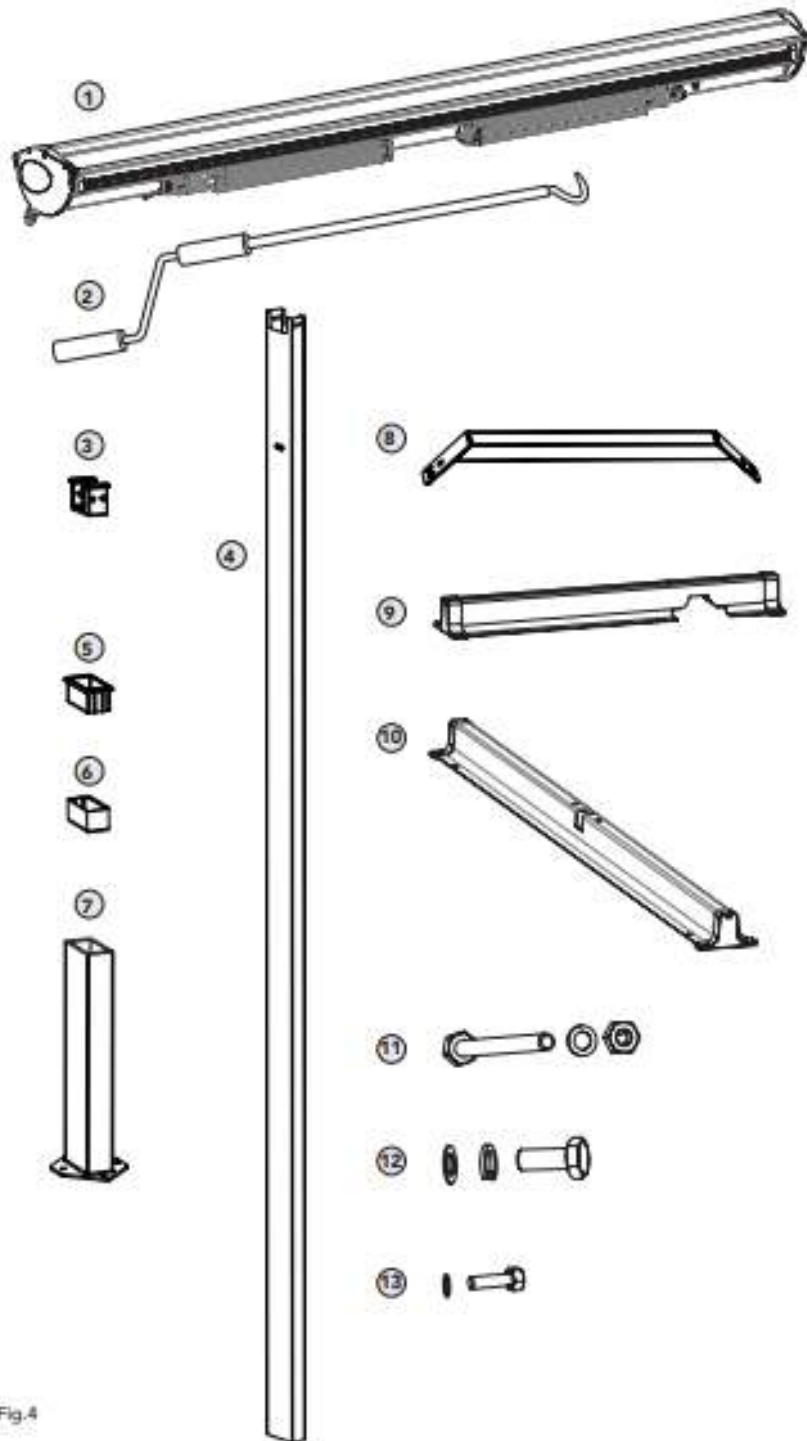

Fig.4

TOOL REQUIREMENTS

Minimum 2 people to install



SUGGESTED TOOLS

- ① Measuring tape
- ② Socket wrench/wrench
- ③ Ladders (2)

OPTIONAL TOOLS

- ④ Drill bit
- ⑤ Masonry drill bit
- ⑥ Drill with bits

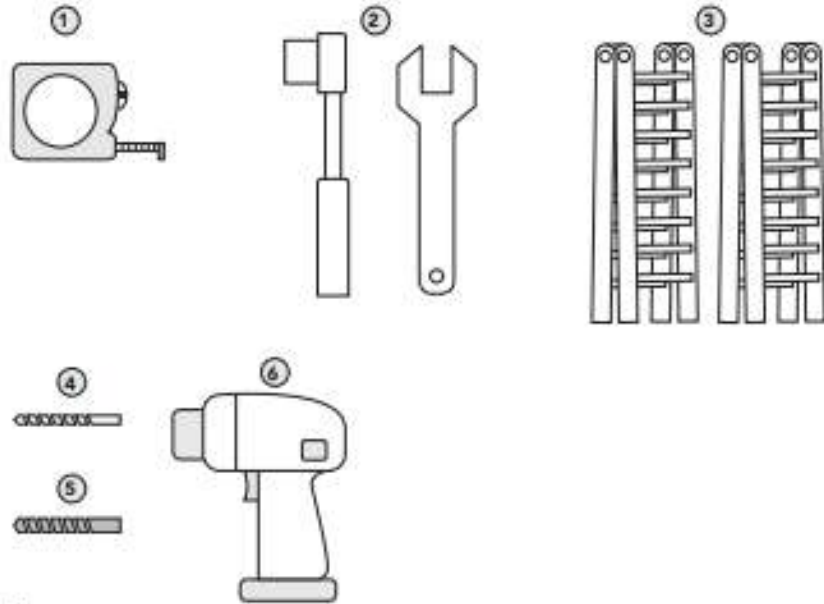

Fig.5

PRODUCT FEATURES

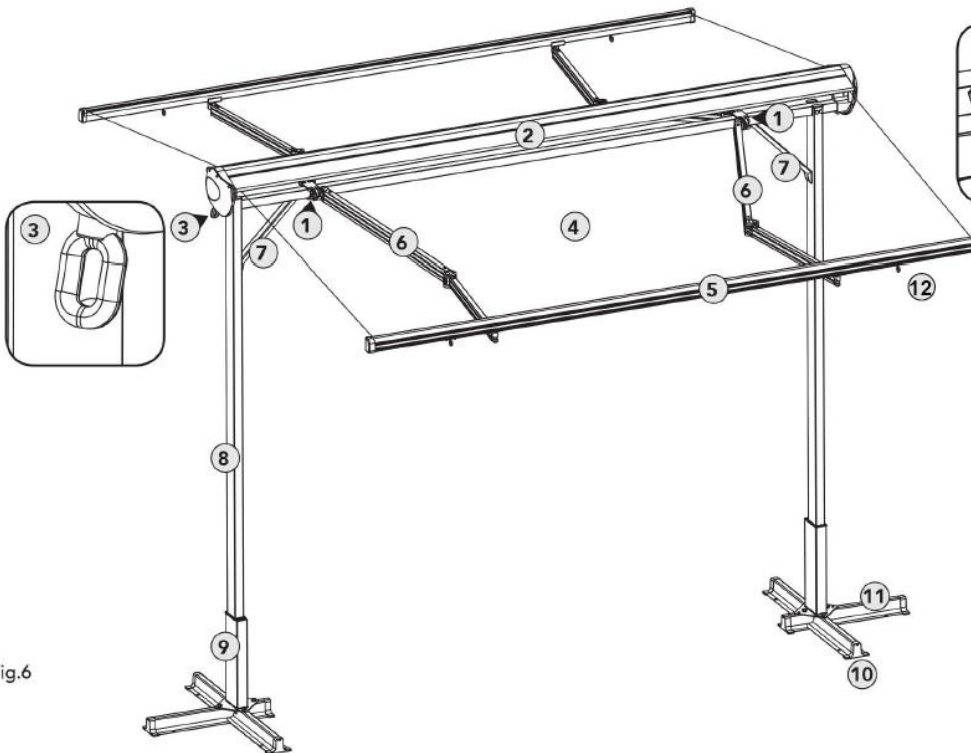

Fig.6

- ① Arm shoulder
- ② Awning module
- ③ Crank loop
- ④ Awning fabric
- ⑤ Front bar
- ⑥ Retractable arms
- ⑦ Supporting brace
- ⑧ Upright leg
- ⑨ Lower leg
- ⑩ Long base
- ⑪ Short base
- ⑫ Screen Hooks

ASSEMBLY

DETERMINE WHERE TO PLACE YOUR AWNING

For 11 x 10 foot model
Locate a clear area, on
level ground / surface,
that is at least 10 feet
wide by 11 feet length by
8 feet height.



Fig 7

For 14 x 10 foot model
Locate a clear area, on
level ground / surface,
that is at least 10 feet
wide by 14 feet length by
8 feet height.

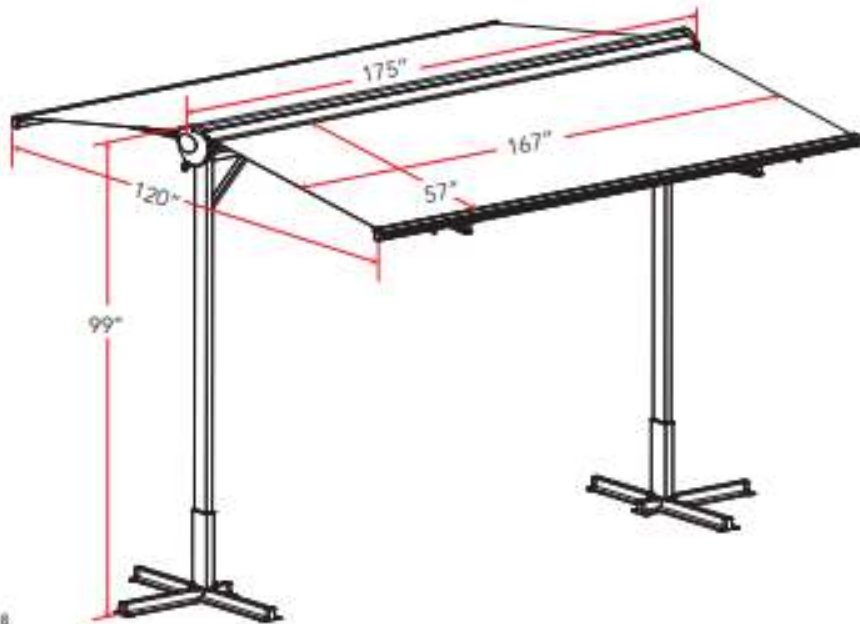

Fig 8

ASSEMBLY

ASSEMBLE THE AWNING SUPPORT STRUCTURE

- ① Slot 1 short base and 1 long base together to create a cross base.
- ② Attach the lower leg to the cross base with 4 lower leg screws and washer sets.
- ③ Insert the upright leg cover into the top of the upright leg.
- ④ Insert the lower leg bottom cover then the top lower leg cover into the lower leg.
- ⑤ Insert upright leg into the assembled leg base.

NOTE: Make sure the screw holes on the upright leg are facing the short segment of the assembled cross base.

- ⑥ Repeat step 1-3 to assemble the second leg base.

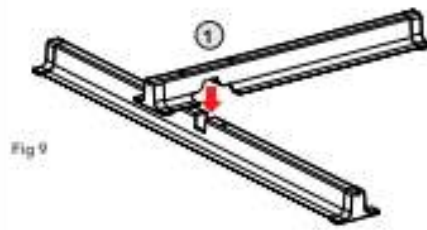

Fig 9

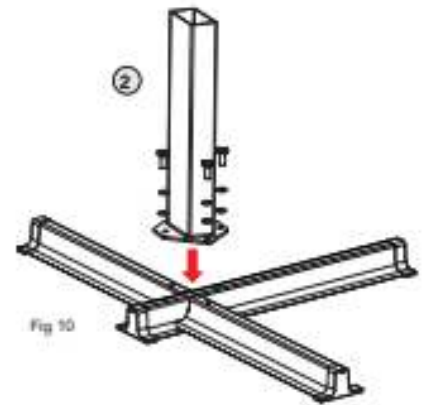

Fig 10

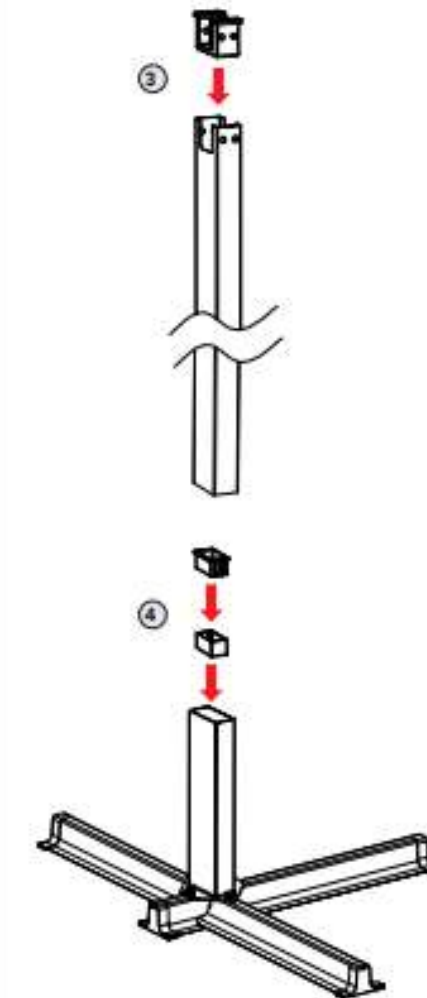

Fig 11

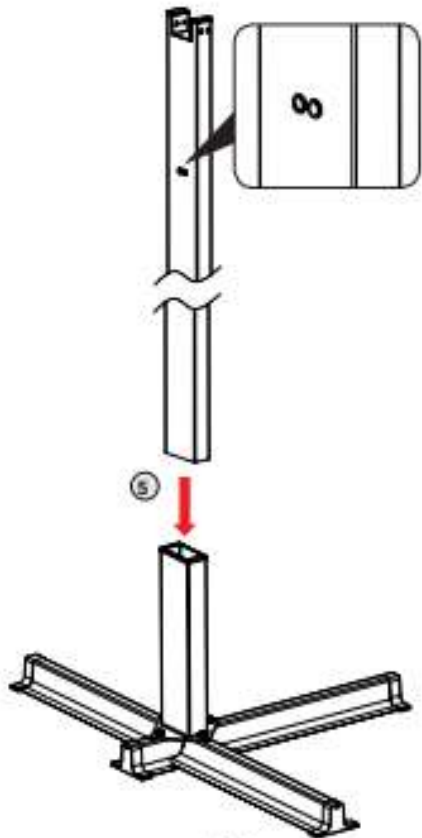
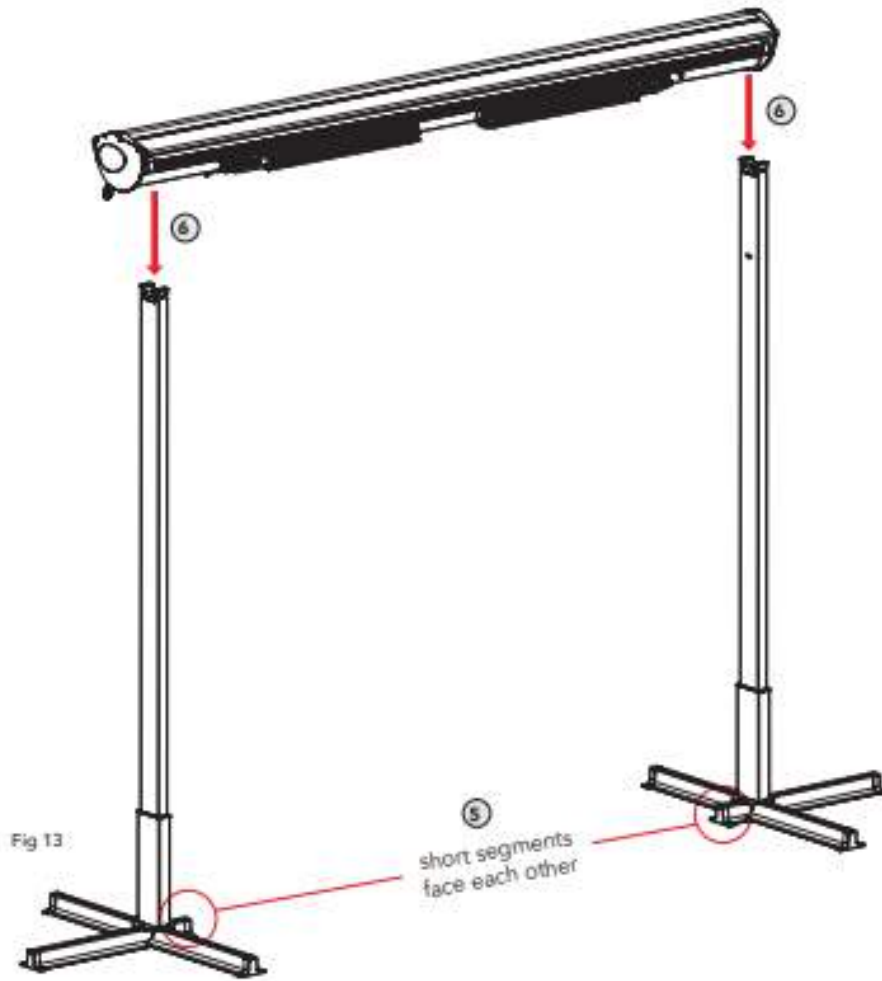

Fig 12

ASSEMBLY

SECURE THE AWNING TO THE SUPPORT STRUCTURE

- ⑤ Place the assembled legs so the short segments of the cross base face each other.
- ⑥ Insert the awning module into the slots on the top of the assembled legs.



- ⑦ Adjust the awning and the legs to align the screw holes.
- ⑧ Attach the awning to the legs using 2 upright leg bolt sets on each leg.

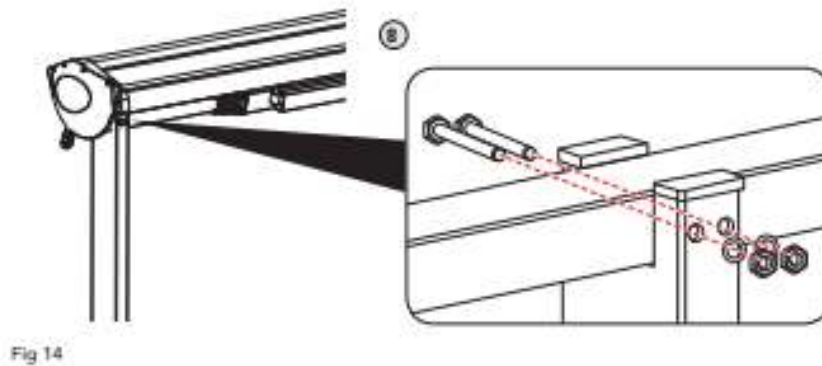

ASSEMBLY

- 9 Place the supporting brace at the upper corners of the awning assembly.
- 10 Align the screw holes and attach the supporting brace to the awning assembly with 2 support brace screw and washer sets for each side.

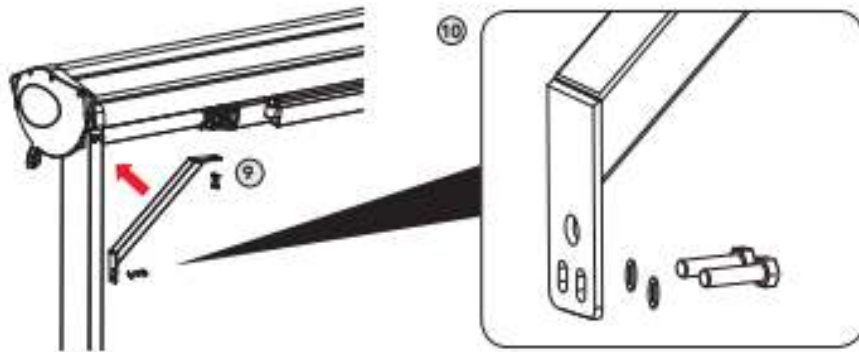

Fig 15

SECURING THE AWNING TO THE GROUND

CAUTION: Make sure the FS Series awning is placed on level ground. Uneven ground will cause the awning to tilt.

Option A

Use screws / bolts / stakes, appropriate to the ground type, to secure the awning cross base onto the ground (earth, concrete, brick, deck).

Note: Screws / bolts / stakes not included in package. Please consult with your home improvement store for appropriate equipments.

Option B

Place concrete pavers onto the awning cross base for security.

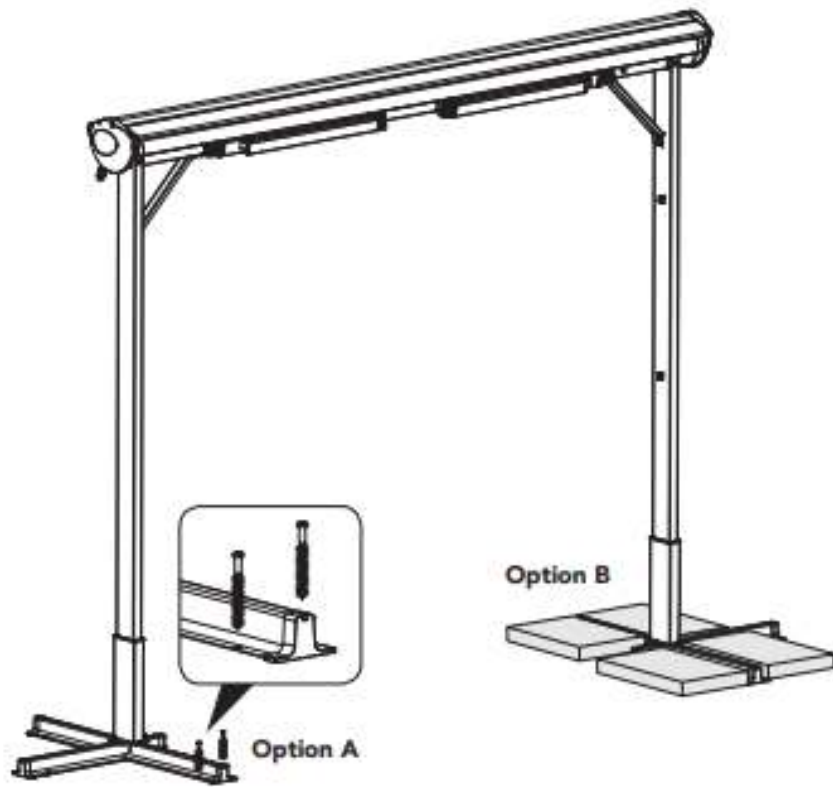

Fig 16

OPERATION

READY YOUR AWNING

Before removing the safety restraints, make sure no persons or objects are in front of the awning. Failure to do so could result in personal injury.

- ① Position yourself under the awning.
- ② Remove the safety restraints from the arms, with scissors, one at a time. Do not use a knife or blade to cut the restraints.

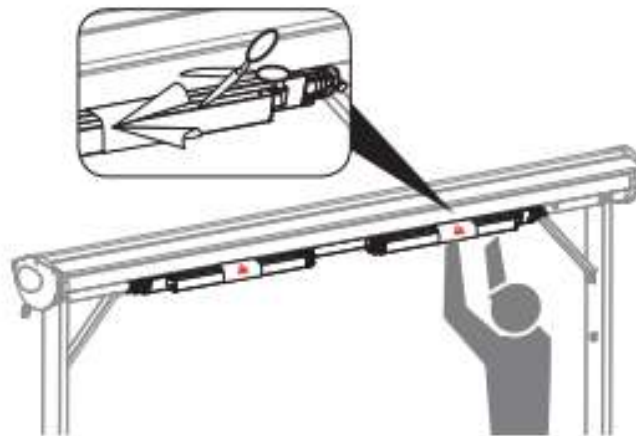

Fig 17

OPERATE YOUR AWNING

- ① Use the hand crank to open the awning fully then close it completely to test for proper operation.
- ② Use the hand crank and open the awning to desired extension.

CAUTION: To keep the fabric taut, always reserve a small portion of the awning fabric in the roller tube.

NOTE: The arms are not designed to be completely straight in the fully extended position.

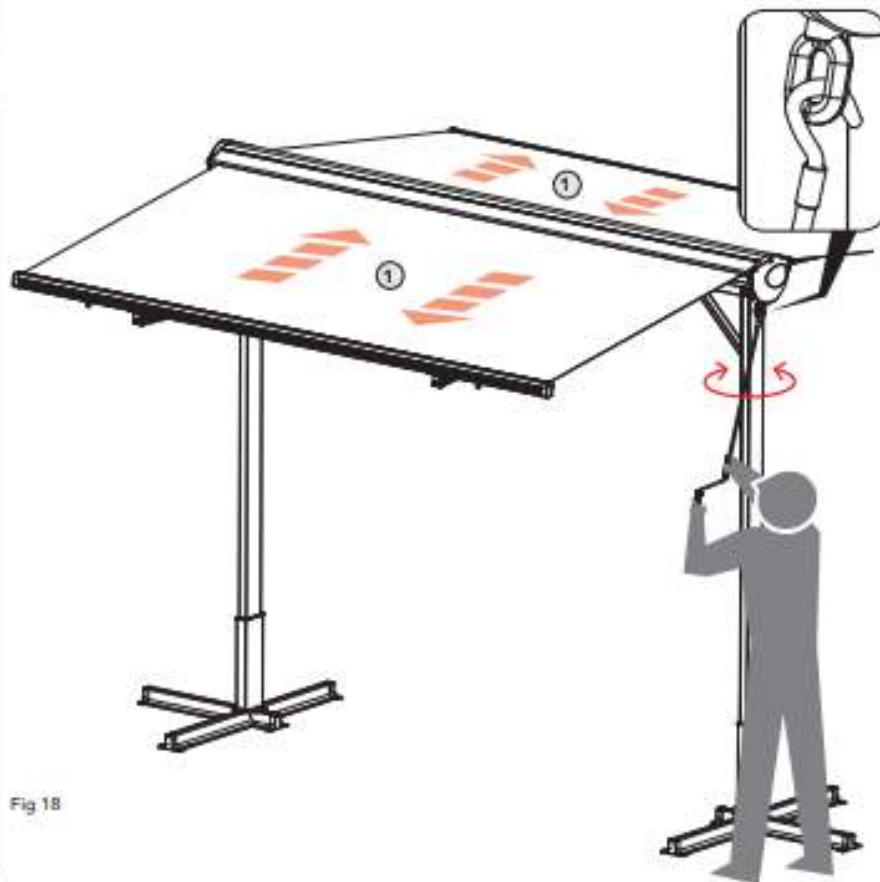

Fig 18

PROJECTION SCREEN INSTALLATION AND REMOVAL

- 1) Hang the DIY Wall 3 with the top hanging loops on the awning's hooks
- 2) Unroll the screen slowly and carefully to avoid damages
- 3) When ready to put away, roll the screen from the bottom and detach from the awning.



Fig 19

MAINTENANCE

PROTECTING THE FABRIC FROM MILDEW

Allow the awning fabric to fully dry before retracting. Doing so will help prevent mildew from growing and prolong the life of the fabric. If you must retract the awning while wet, open the awning as soon as the weather permits to allow the fabric to fully dry and remove any dirt deposits to preserve the fabric.

CLEANING THE FABRIC

Cleaning the awning regularly with mild soap and water will extend the life of the fabric and prevent the formation of mildew. It is necessary to prevent stains from becoming embedded into the fabric. Remove the dust from the dry awning fabric by gently beating or brushing the fabric.

PROTECTING THE FRAME

Your awning contains powder-coating steel or aluminum and can last for many years. It is important to inspect the fasteners, connections and the condition of the metal components.

PREPARING YOUR AWNING FOR INCLEMENT WEATHER

The retractable awning is designed to provide protection from the sun and is not intended for rain, snow or extreme wind. Retract the awning to prevent damage from accumulated water, snow or from strong gusts of wind. The fabric is water repellent and is not intended to protect against the water elements.

LIMITED WARRANTY COVERS (Awning only)

For warranty coverage on the Outdoor Projection Screen, visit www.elitescreens.com/warranty

Elite Screens warrants all Yard Master Awning original products, sold and installed within the 50 states of the United States, to be free of defects of materials and workmanship. This warranty only applies to the original owner or purchaser of the product and is only effective on a basis for sixty (60) months or five (5) years from the date of purchase. Any defects or issues presented to Elite Screens within the warranty period will be handled by Elite Screens Customer Service within a reasonable time.

Entire awning framework, including extruded and die cast component parts, springs and cables are covered under the limited warranty. Should the purchaser notify Elite Screens within the twelve (12) months or one (1) year period from the date of the original purchase, defective component will be replaced in full or repaired by Elite Screens at no charge. All claims submitted after twelve (12) months or one (1) year but within sixty (60) months or five (5) years from the date of the original purchase, the defective component will be replaced upon the purchaser's payment of 1/60th of the full retail cost of the component for each month of use prior to the claim. Powder coated finishes and painted finishes are excluded and are NOT covered under this limited warranty.

ANY MODIFICATIONS OR ALTERATIONS TO THE PRODUCT WILL VOID THIS WARRANTY. ELITE SCREENS, INCLUDING ITS SUBSIDIARIES AND AFFILIATES SHALL NOT BE RESPONSIBLE IN ANY MANNER WHATSOEVER FOR INJURY, DEATH OR DAMAGE TO PROPERTY AS A RESULT OF THE INTENTIONAL OR ACCIDENTAL MISUSED FOR PURPOSES FOR WHICH THE PRODUCT WAS NOT DESIGNED FOR.

WARRANTY LIMITATION AND EXCLUSIONS

The warranty will be in effect once the Yard Master Awning is fully paid for.

Elite Screens is not responsible for damages due to faulty modifications, installation, or re-installation.

Elite Screens assumes no liability for damage to the structure to which the awning is attached, or to the property located underneath the awning. This limited warranty does not cover damage from ice, snow, hail, high winds, vandalism, neglect, improper use, or any natural disasters. This limited warranty does not cover degradation due to salt corrosion, oxidation, and chipping or peeling of the paint.

Problems and Warranty Claims

If you experience a problem with your Yard Master Awning product, please contact Elite Screens Customer Service over the phone Monday through Friday 8:00AM – 4:00PM Pacific Standard Time at 1-562-483-8198 or email us at service@elitescreens.com.

- Prior to contacting Elite Screens via phone or email for warranty claims, please have your model number, serial number, original proof of purchase, and a description of the problem for our Customer Service team. Most issues can be resolved over the telephone by our trained Customer Service representatives. If any issues arise that cannot be solved over the phone or email, Elite Screens will issue a Return Merchandise Authorization ("RMA") number and arrange replacement parts for you. For more information on returning a product for warranty repair, please visit www.elitescreens.com
- All Work will be carried out by Elite Screens and will not extend the warranty coverage period beyond the sixty (60) months from the original date of purchase. Any work done by a third party or non-authorized Elite Screens agent will void this warranty

THIS WARRANTY IS EXCLUSIVE AND IS IN LIEU OF ANY AND ALL OTHER WARRANTIES, EXPRESSED OR IMPLIED. NO IMPLIED WARRANTIES OF MERCHANTABILITY OR FITNESS FOR A PARTICULAR PURPOSE ARE GIVEN, ANY AND ALL LIABILITY FOR BREACH OF ANY IMPLIED WARRANTY OR WARRANTY CREATED BY LAW IS DISCLAIMED.

Some states do not allow limitations on how long an implied warranty lasts, so the above limitation may not apply to you.

UNDER NO CIRCUMSTANCES SHALL ADVANING, INCLUDING ITS SUBSIDIARIES AND AFFILIATES BE LIABLE FOR INCIDENTAL OR CONSEQUENTIAL DAMAGES WITH RESPECT TO ECONOMIC LOSS, INJURY, DEATH OR PROPERTY DAMAGE, WHETHER AS A RESULT OF BREACH OF THIS WARRANTY, NEGLIGENCE OR OTHERWISE.

Some states do not allow the exclusion or limitation of incidental or consequential damages, so the above limitation or exclusion may not apply to you in whole or in part. This warranty gives you specific legal rights. You may also have other rights that vary from state to state.

What is Not Covered by the Elite Screens Limited Warranty

This warranty is non-transferable and does not cover product purchases from the initial buyer to a third party. This warranty does not cover incidental damages, such as loss of time, loss of use, or installation costs of defective, repaired or replaced product.

This warranty does not cover product that has been damaged or rendered defective as a result of:

- (a) Neglect, abuse or misuse.
- (b) Modification of the original product.
- (c) Improper use or installation using products not manufactured by Elite Screens.
- (d) Service provided by anybody other than Elite Screens.
- (e) Abnormal mechanical or environmental conditions.
- (f) Unusual physical or electrical stress -including failure or fluctuation of electrical power, lighting, static electricity, fire, tornadoes, or other natural disasters.

Shipping Damage Claim: In the occasion of a damage claim, the end user must contact Elite Screens and the delivering freight carrier within 3 days of signing for the delivery in order to make a claim. Failure to report freight damage and missing parts in a timely manner and in accordance to the carrier's guidelines may result in you incurring all costs.

Likewise, there are 7 days to report missing parts to Elite Screens.

If warranty, shipping damage, or technical support is needed please fill out our form at www.elitescreens.com/warrantysupportform