



Sable Frame CineGrey 3D® Series

ezFrame CineGrey 5D® Series

*Ceiling Ambient Light Rejecting (CLR®/ALR) Fixed Frame Screen*

*USER'S GUIDE – M Type*

**V3**

Congratulations on your new *ezFrame/Sable* Frame purchase! The screen material included is our **award winning GREENGUARD GOLD and ISF Certified** CineGrey 3D®/5D® which is a front projection material, precisely formulated for environments with minimal control over room lighting. It was designed to **enhance picture brightness, offer accurate color fidelity, and improve contrast levels**. The CineGrey 3D®/5D® is best for family rooms, educational facilities, conference rooms, house of worship or any applications in which incident light is a factor.

In order for the *CineGrey 3D®/5D®* to maintain its projection qualities and optimum performance please refer to the list below for proper maintenance and cleaning.

- Use a dry microfiber cloth to remove dust from the screen's surface.
- When cleaning, use a damp microfiber cloth with warm water to remove any marks.
- Never rub or apply pressure when cleaning the surface.
- Never attempt to use any solutions, chemicals or abrasive cleaners on the screen surface.
- In order to avoid damaging the screen, avoid touching it directly with your fingers, pens/pencils or any other sharp or abrasive objects.

### Frame Parts List

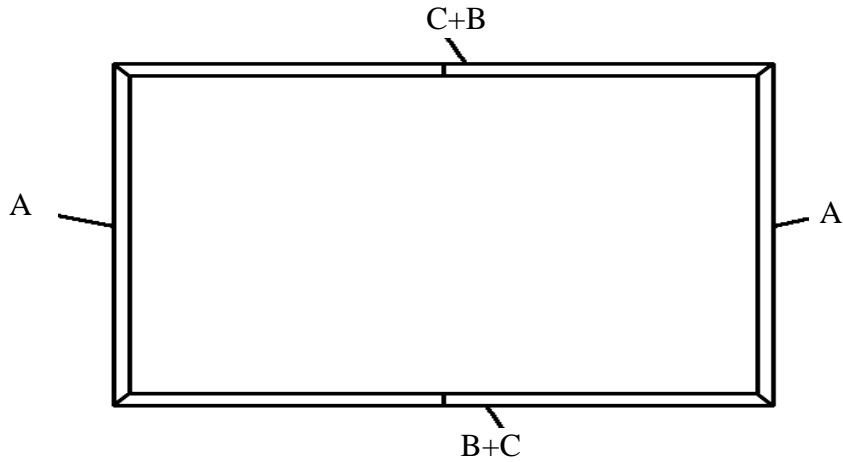
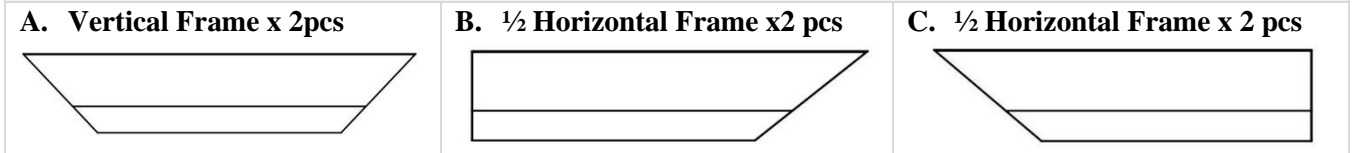

### Hardware Parts List

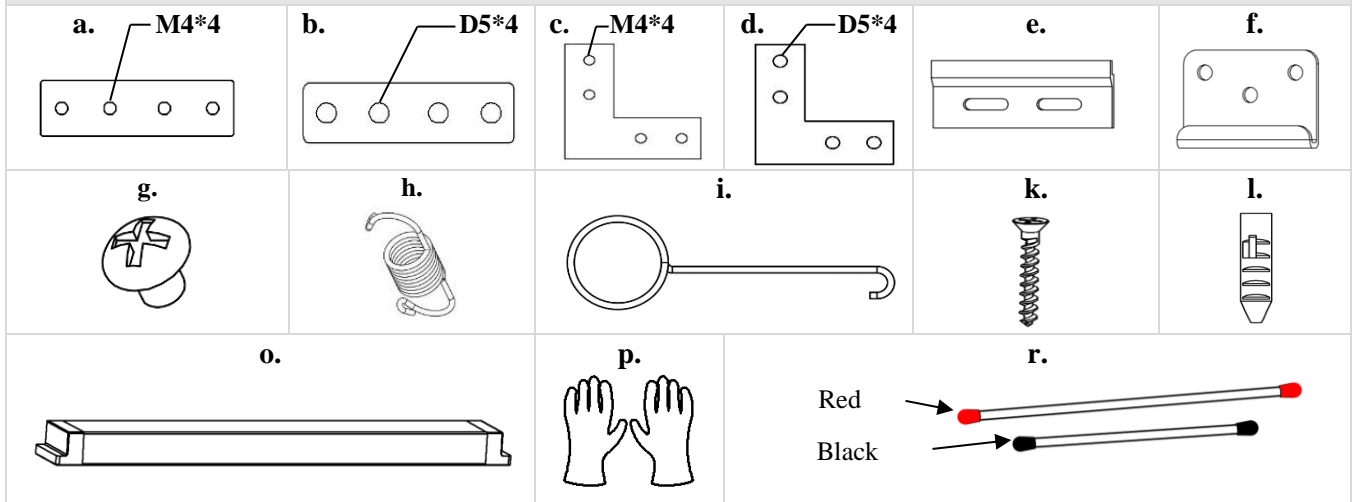

Item	Parts List	92"	100"	110"	120"	135"	150"	165"	180"	200"
<b>a.</b>	Center Joints- M4 (bottom position)	2	2	2	2	2	2	2	2	2
<b>b.</b>	Center Joints-D5 (top position)	2	2	2	2	2	2	2	2	2
<b>c.</b>	Elbow Joints M4 (bottom position)	4	4	4	4	4	4	4	4	4
<b>d.</b>	Elbow Joints D5 (top position)	4	4	4	4	4	4	4	4	4
<b>e.</b>	Top hanging brackets	2	2	2	2	2	2	3	3	3
<b>f.</b>	Bottom brackets	2	2	2	2	2	2	3	3	3
<b>g.</b>	M4x7 Screws	24	24	24	24	24	24	24	24	24
<b>h.</b>	Spring	56	60	66	72	80	88	100	106	116
<b>i.</b>	Pull Hook	2	2	2	2	2	2	2	2	2
<b>k.</b>	Wall Screws M5x50	8	8	8	8	8	8	12	12	12
<b>l.</b>	Hollow Wall anchors	8	8	8	8	8	8	12	12	12
<b>o.</b>	Center Support Bar	1	1	1	1	1	1	2	2	2
<b>p.</b>	White gloves	2	2	2	2	2	2	2	2	2
<b>r.</b>	Φ3 mm Long Iron (sides) rod / Short rod (top/bottom)	2/4	2/4	2/4	2/4	2/4	2/4	2/4	2/4	2/4

## Frame Assembly

**Step 1:** Place the EPE sponge (foam) sheet on the ground of the area where the screen will be assembled.

**Step 2:** Position the pieces of the frame on the EPE sponge in the arrangement shown below.

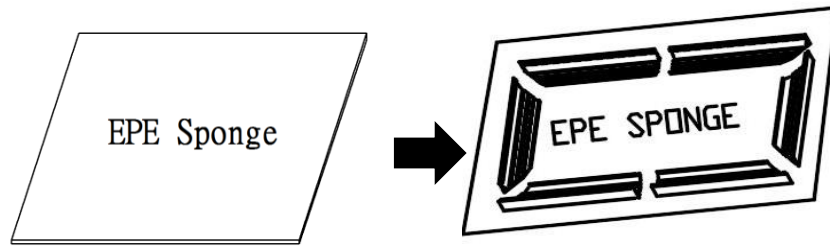

**Step 3:** Insert *center joint* (a/b) connectors into *one-half of the horizontal frame* (B/C) and secure with the *M4x7 screws* (g) as shown in the illustration below.

**Tip:** The *center joint (b)* with the larger diameter holes should be on top.

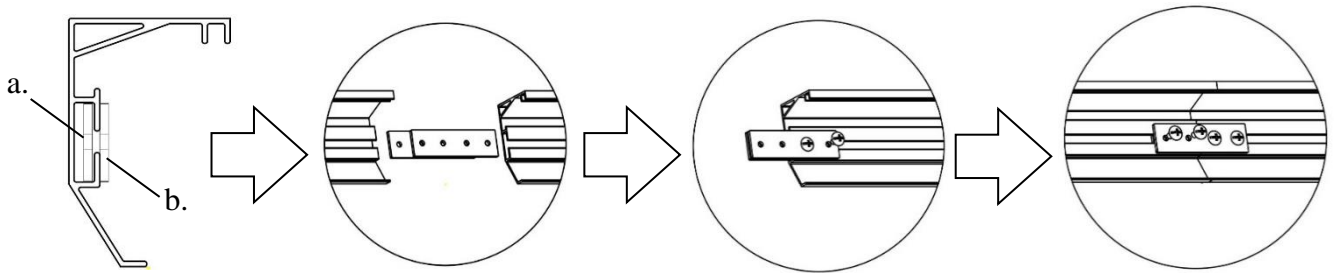

**Step 4:** Connect the *elbow joints (c/d)* to the top and bottom sections of the vertical frame. Once inserted, connect the vertical sections to the horizontal frame sections. Make sure all holes are in alignment and the frame pieces are flush (no gaps). They should form perfect right angles.

**Tip:** The *elbow joint (d)* with the larger diameter holes should be on top.

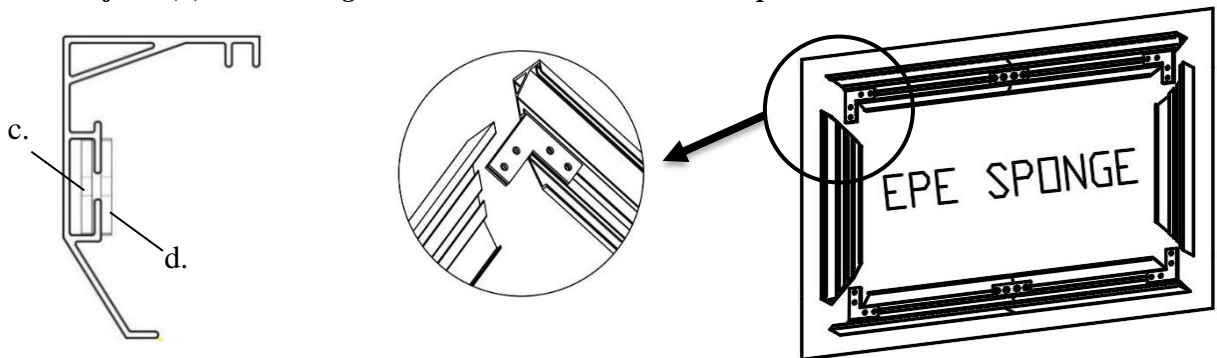

**Step 5.** Secure the elbow joints by fastening them with *M4x7 screws* (g), 4 at each corner.

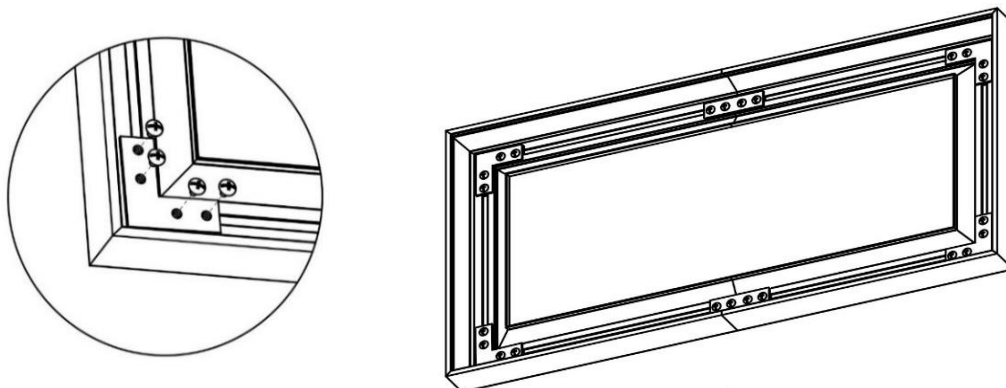

## Screen Material

**Step 6:** Put on the *white gloves (p)* and carefully unroll the screen material on a clean surface from the roller to the other side as shown below. The back side of the screen material should be placed upwards. Then place a *bottom grommet (r)* on the screen material's eyelet and snap in the *top grommet (s)* as shown below. Repeat the process for all eyelets.

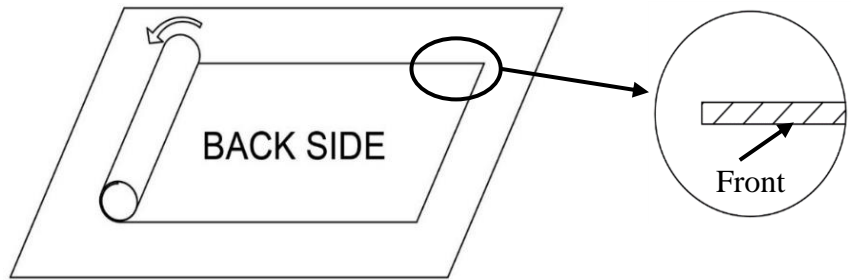

**Step 7:** Carefully place the screen on top of the assembled frame as shown below. Make sure that the angular edges of the frame are not allowed to come into direct contact with the screen material to avoid puncturing.

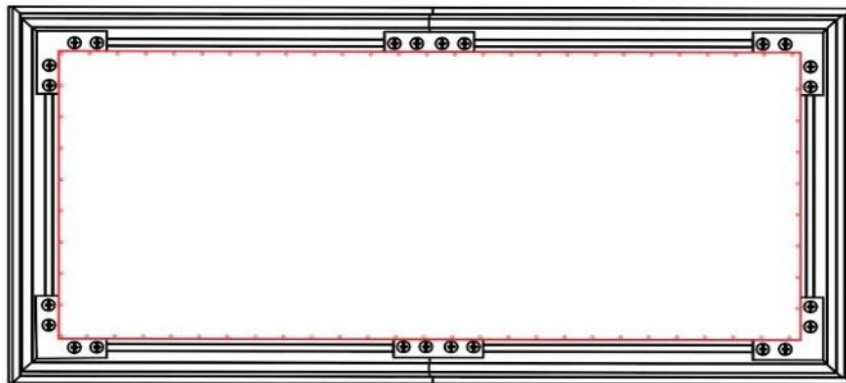

**Step 8:** Insert the *rods (r)* through the sleeves according to their corresponding lengths on each edge of the screen as shown below. The short rods (top/bottom) will overlap to secure a firm grasp in the middle areas.

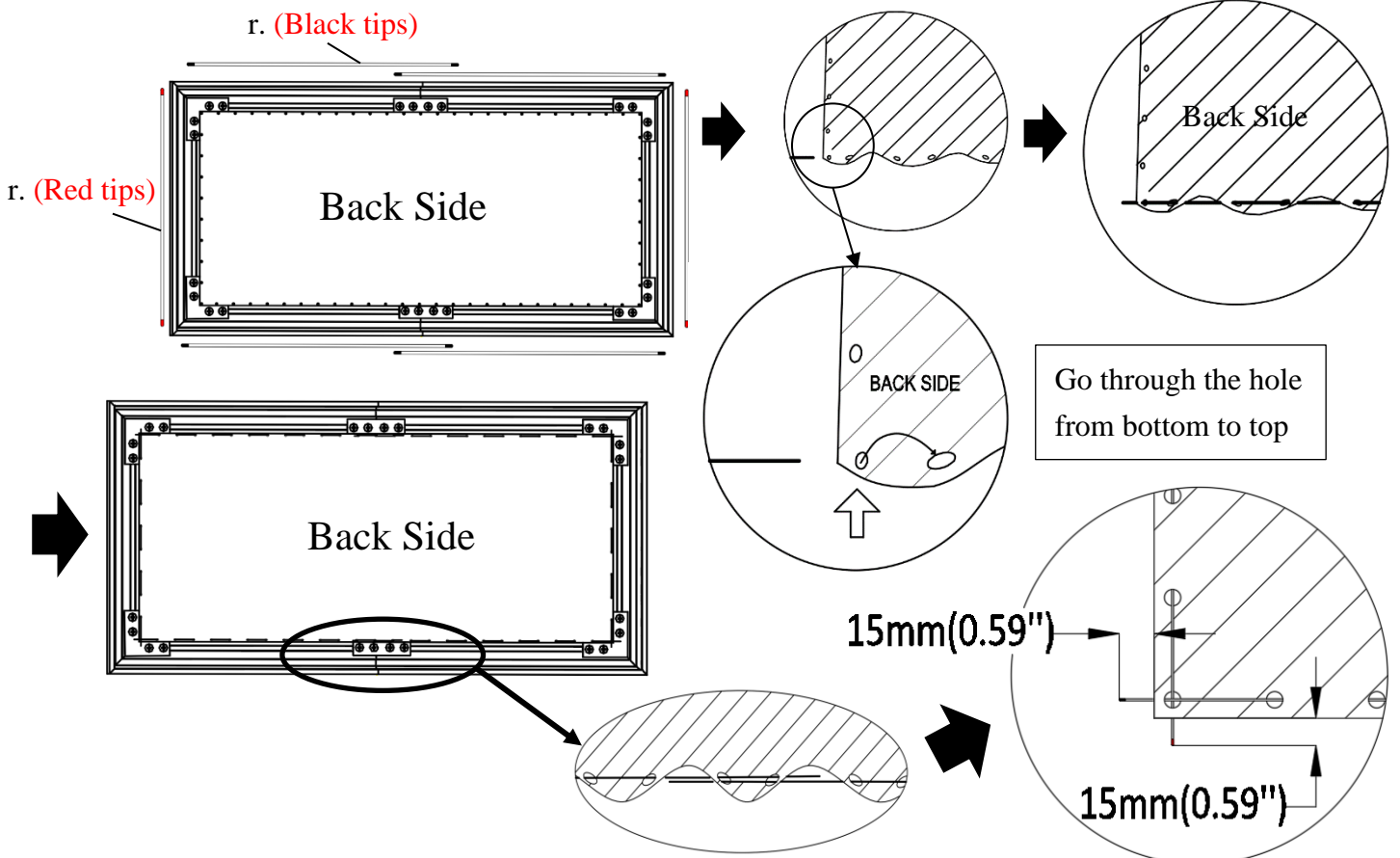

## How to attach the springs

**Step 9:** Hook one end of the spring and secure inside the groove of the frame, use the *spring hook (i)* to attach the spring to the hole located on the screen material's outer edge in the following order.

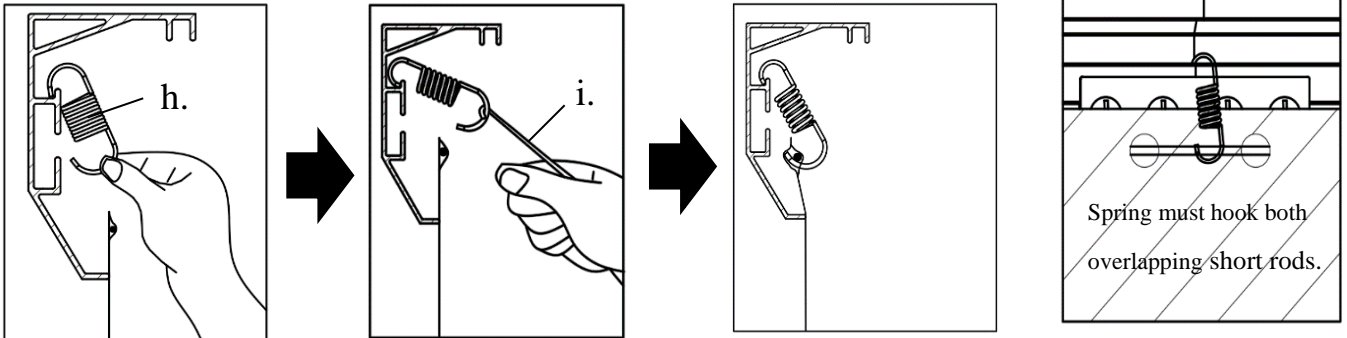

First connect on four corners, steps 1-4. make sure all four corners are fixed before proceeding with next spring.

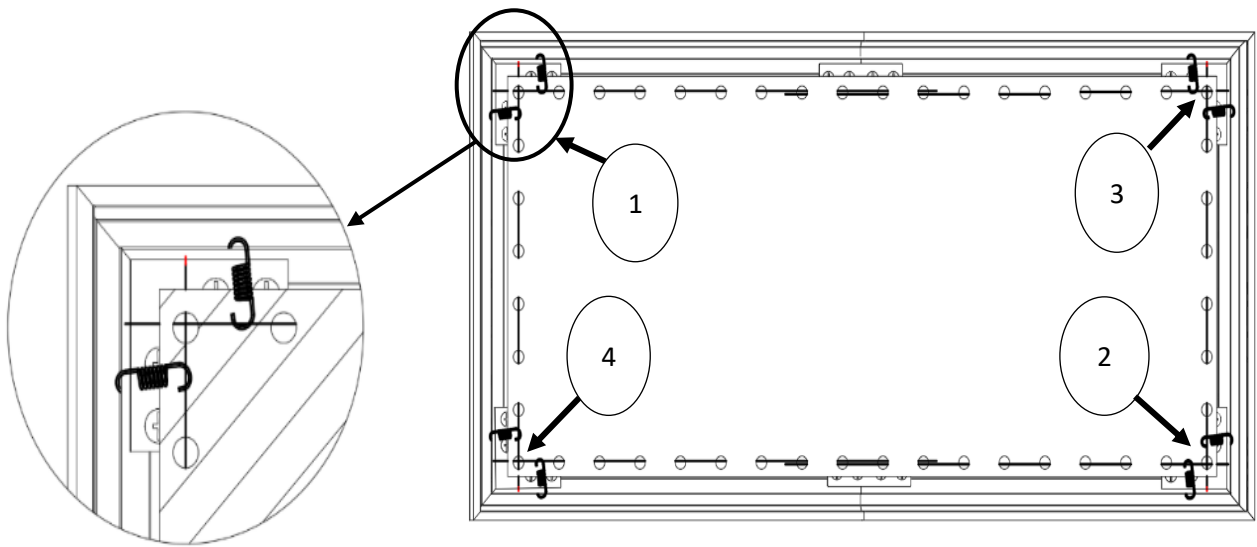

Continue to attach the remaining springs to the material in steps 5-12 in the follow order.

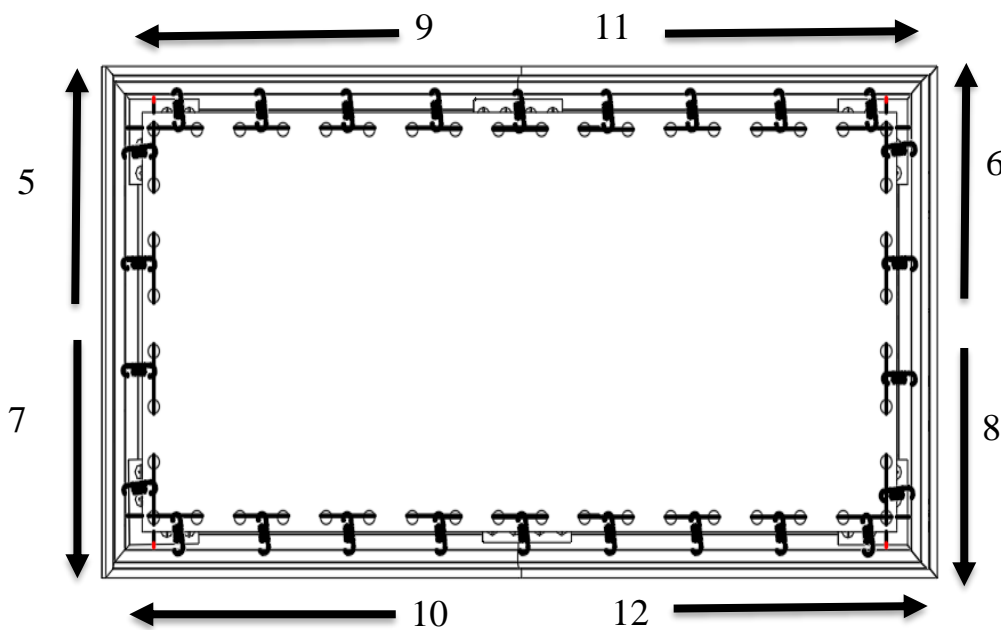

**Step 10:** Insert the Center Support Bar (o) into the upper top groove on the back of the frame with the bottom end near the approximate center point of the frame and rotate it in at an angle so that both ends of the bar are in alignment with the groove.

**Diagonal Models 150" and below use 1 x Center Support**

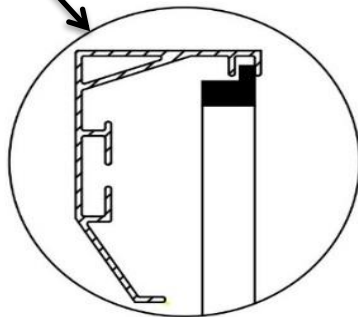
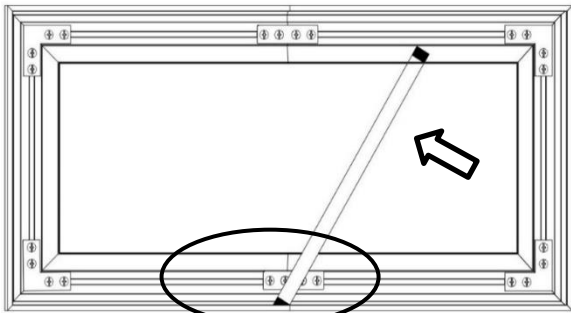

**Diagonal Models above 150" require 2 x Center Support Bars**

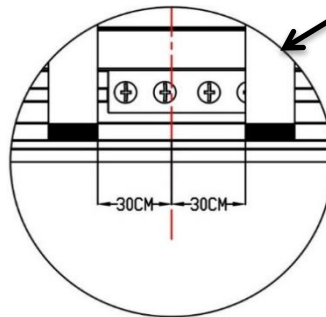
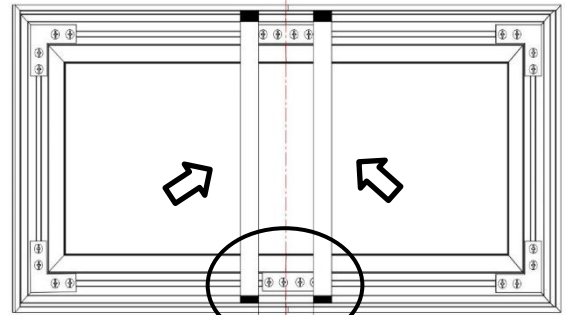

Place a center support bar 30 cm (11.8") apart from the center (red line).

**Notice to Installer:**

Please use the following installation instructions to obtain superior optical performance from the CineGrey 3D/5D Angular Reflective ALR (Ambient Light Rejecting) Screen

Make sure to follow these instructions in order for the CineGrey3D/ 5D to perform correctly.

1. Ambient Light must not come from the same direction as the projector's light
2. Minimum Lens Throw Ratio of 0.8x image width.

*Note: To use short-throw projectors, you will need a minimum 0.8 lens throw ratio or greater*

3. Not compatible with Ultra-Short Throw Projectors

**Projector Ceiling Installation:** Make sure the projector (*light in*) is angled ( $\Theta 1$ ) to reflect ( $\Theta 2$ ) at the mirror-opposite angle (*light out*) to align with the viewer's eye level.

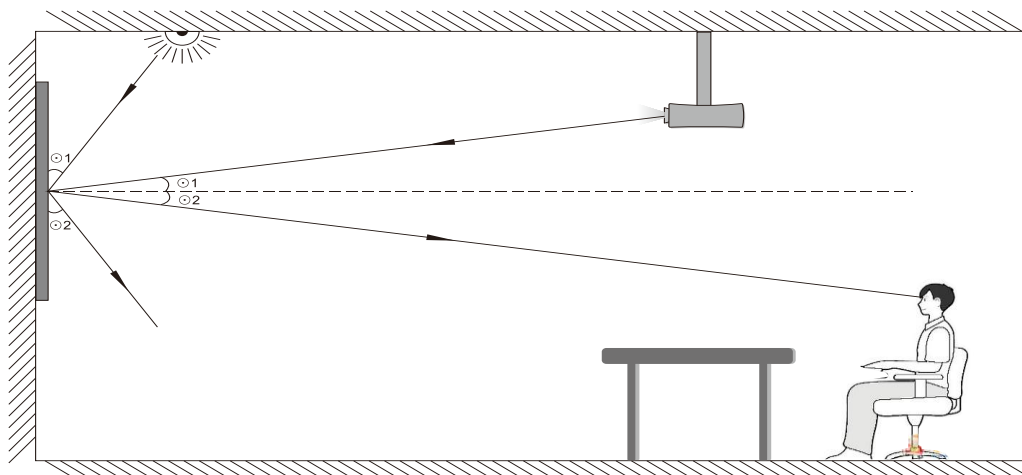

**Projector Tabletop:** Make sure the projector (light in) is angled ( $\Theta 1$ ) to reflect ( $\Theta 2$ ) at the mirror-opposite angle (light out) to align with the viewer's eye level.

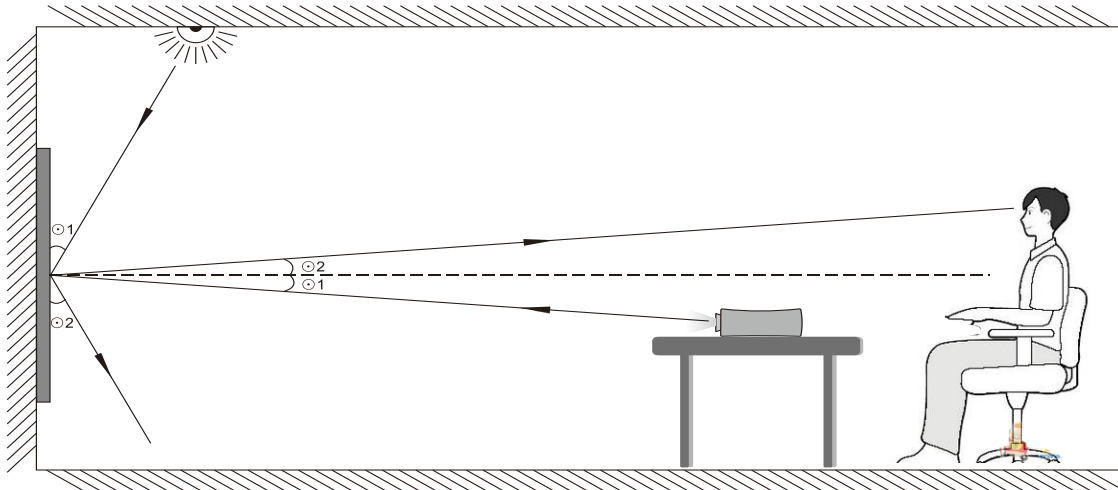

**Images are not up to scale and are for illustrations purposes only.**

**Note:** Improper installation will result in light loss and produce a dark image. This is due to the projector's light reflecting in the wrong direction.

## Installation

**Step 11:** Measure the overall length and height of the frame and drill holes for the top brackets. Line up the wall brackets with the drilled holes on the installation location and screw them in using a Phillips screwdriver. If not installing into a structural wood stud, use a hollow wall anchor then screw in the M5x50 wood screws with a screwdriver. Make sure the brackets are leveled.

### **Diagonal Models 150" and below use 2 x Top hanging brackets**

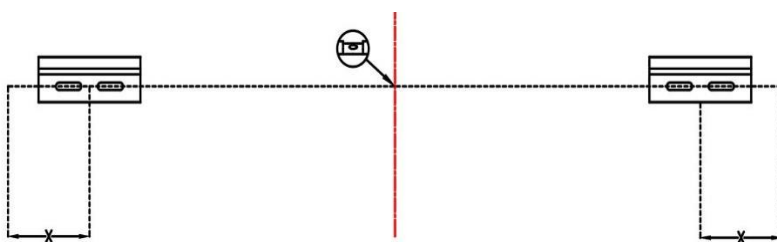

### **Diagonal Models 150" require 3 x Top hanging brackets**

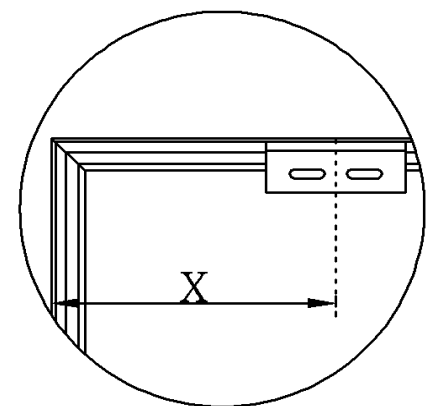
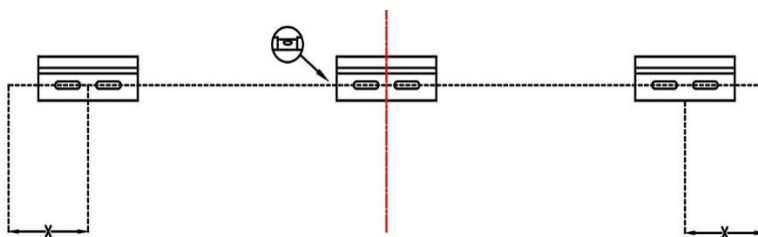



**Step 12:** Position the fixed frame screen onto the top wall brackets as shown below and push down at the center of the top of the frame to secure.

**Diagonal Models 150" and below use 2 x Top hanging brackets**

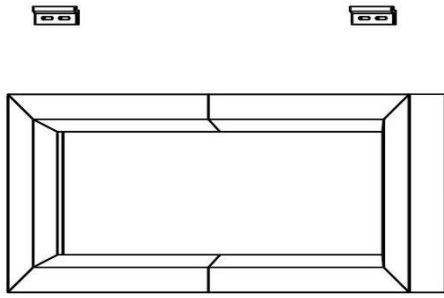

**Diagonal Models 150" require 3 x Top hanging brackets**

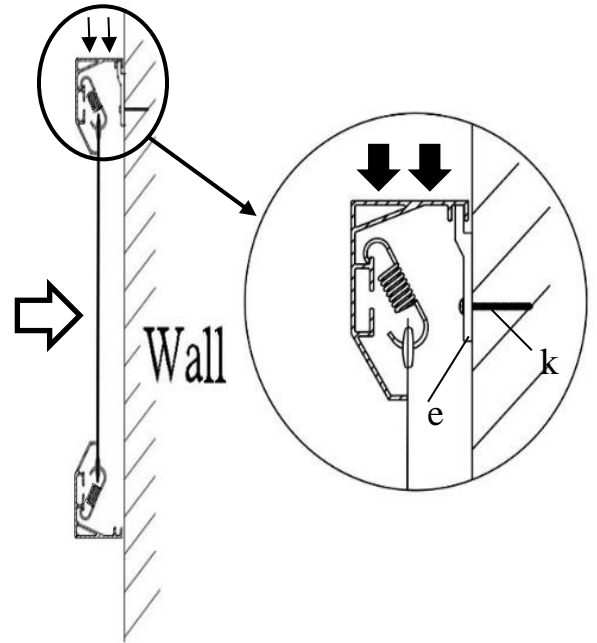
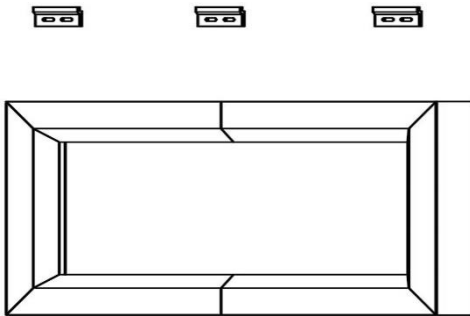

**Step 13:** With the frame slightly tilted outward; connect the bottom brackets onto the bottom groove of the frame. Slowly return the screen to a normal upright position. Once the screen is flush to the wall, secure the brackets to the wall with a screw. If not installing into a structural wood stud, mark the sites where the hollow wall anchors will be placed using the same instructions above. With the wood anchor installed, repeat the process and fasten the brackets with the M5x50 wood screws.

**Diagonal Models 150" and below use 2 x Bottom**

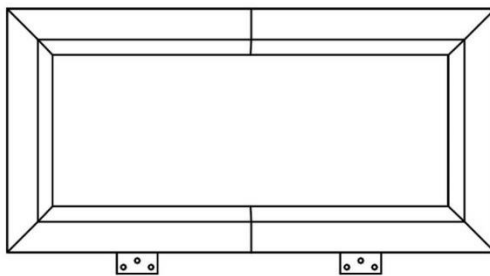

**Diagonal Models 150" require 3 x Bottom brackets**

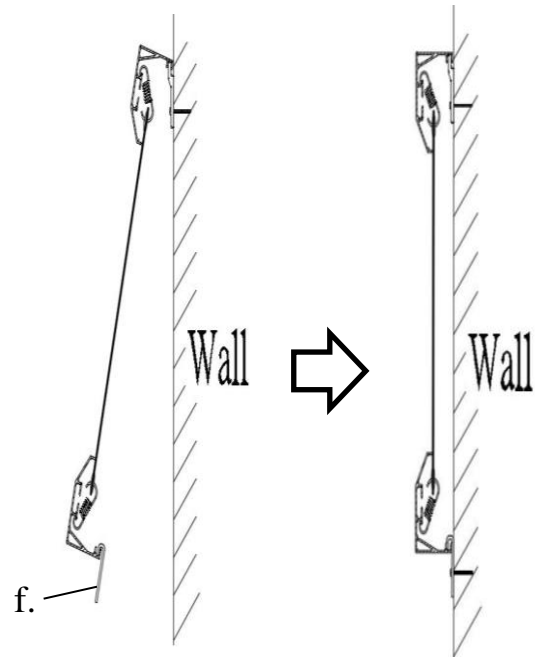
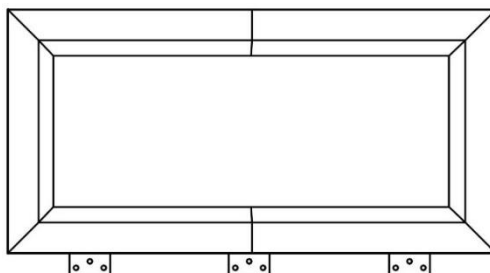

**For Technical Support or an Elite Screens contact in your area, visit [www.elitescreens.com](http://www.elitescreens.com)**