



# Lights-On Portable Series®

Folding-frame model: LPS123H-SBCLR16

Portable Indoor Ceiling Ambient Light Rejecting Screen

## User's Guide – M type V1.0

Visit [www.elitescreens.com](http://www.elitescreens.com) for latest updated version.

Thank you for choosing the *Lights-On Portable Series*® projection screen! The screen material included is our **StarBright CLR® 16**, which is an optical lens front projection material precisely formulated for environments with minimal control over room lighting. It was designed to filter and absorb overhead light while reflecting projector light from standard throw projectors. It is best for family rooms, educational facilities, conference rooms or any applications in which incident light is a factor.

Please read through this user guide before utilizing the screen. Correct usage and maintenance will ensure a long product life.

### Storage and Cleaning Instructions

#### *Storage Conditions*

**StarBright CLR® 16** is primarily composed of optical-grade PET (Polyethylene Terephthalate) combined with UV-molded resin, and it exhibits hygroscopic properties. Environmental factors such as humidity and temperature can affect its structural integrity and optical properties. Therefore, please adhere to the following conditions during both installation and storage:

- **Temperature Variations:** Keep temperature fluctuations within a range of no more than 41°F (5°C) per day to avoid undue stress on the material.
- **Avoid Excessive Relative Humidity:** Prevent exposure to high relative humidity levels to preserve the product's quality and performance.
- **Limited Storage Duration:** Do not store the roll material for more than 1 year to maintain its optimal characteristics.
- **Recommended Temperature and Humidity Levels:**

Please refer to the table below for recommended temperature and humidity ranges.

| Item              | Storage conditions    |
|-------------------|-----------------------|
| Temperature       | 50° - 95°F (10°-35 C) |
| Relative Humidity | 25 - 80%              |

#### *Surface Cleaning*

Extended exposure of this product to the atmosphere may lead to localized accumulation of dust or impurities, which can affect the viewing experience. To maintain optimal surface cleanliness, you can employ the following methods:

- **Use a Soft Cleaning Brush:** Gently brush the surface with a soft cleaning brush to remove any surface-adhered dust or impurities.
- **Damp Cloth Cleaning:** Dampen a clean, soft cloth with water and wipe the surface. Afterward, use an air gun or dust blower to ensure thorough drying.
- **Adhesive Dust Removers:** Utilize adhesive dust removers or traceless adhesive tape to pick up and remove any dust or impurities adhering to the surface.

By following these cleaning methods, you can ensure that the product remains free from surface contaminants and maintains its optimal viewing quality, even after extended exposure to environmental conditions.

**Notes: Elite Screens is not responsible for damages due to negligence resulting from misuse or mishandling of the product and will void your warranty.**





- Don't **touch** the screen material with your bare hands to avoid leaving oil residue from fingertips.  
*Use gloves when handling the material.*
- Don't **point** to the screen material with a fingertip or other sharp objects to prevent damage to the material.
- Don't **use** acetone, benzene, alcohol and any other organic solvents to clean the screen material. Using such chemicals will permanently damage the screen.
- After using the screen, disassemble it and store it in the carrying bag provided.
- To avoid damage and injury, the screen should only be operated by adults.

## Product Description

**Design:** The aluminum frame is designed to be light weight and easy to handle when setting up or taking it down. Portability makes the screen easy to carry.

**Screen Fabric:** The screen fabric is attached to the rectangular frame and held in place by Velcro which ensures an evenly stretched and flat surface. The **StarBright CLR® 16** (front projection) screen material is delicate and should be carefully rolled to avoid any damage to the surface.

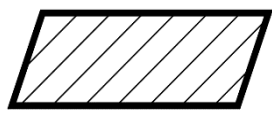
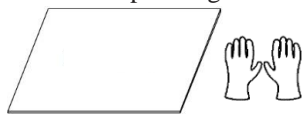
### Hardware and Parts List

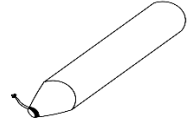
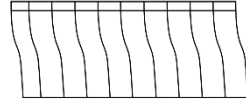
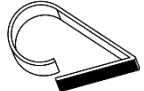
|   |  |   |  |  |
|---|--|---|--|--|
| <p>A. Folding frame</p>  | <p>B. Left /Right folding legs</p>  | <p>C. Projection screen material</p>  | <p>D. Protective foam sheet and pair of gloves</p>  |  |
| <p>E. Carrying Bag</p>   | <p>F. Knob screw</p>                | <p>G. Screen material bag</p>          | <p>H. Skirt</p>                                      | <p>I. Skirt hook</p>  |

| Item | Parts List                               | 103" | 123" |
|------|--|------|------|
| A.   | Folding frame                            | 1    | 1    |
| B.   | Left and right folding legs              | 2    | 2    |
| C.   | Projection screen material               | 1    | 1    |
| D.   | Protective foam sheet and pair of gloves | 1    | 1    |
| E.   | Carrying Bag                             | 1    | 1    |
| F.   | Knob screw                               | 8    | 8    |
| G.   | Screen material bag                      | 1    | 1    |
| H.   | Skirt                                    | 1    | 1    |
| I.   | Skirt hook                               | 5    | 7    |

Note: The parts list above is subject to change without notice.

## SETUP /ASSEMBLY TIPS

- ◆ Elite Screens highly recommends two people to assemble the screen.
- ◆ Make sure to keep the material protection film and tube for disassembling the screen and repacking use.

## Frame Assembly and Screen Material Attachment

1. Take the folding frame (A) out of the carrying bag (E) and place it on a flat surface. Unfold the longer sections first. (Fig. 1-3).

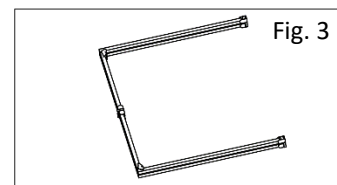
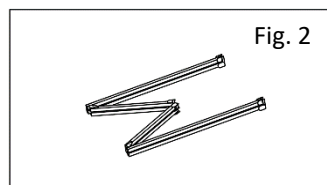
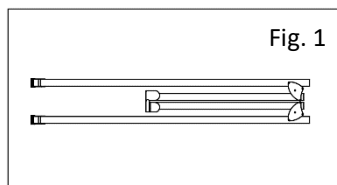

2. Unfold the frame until the latch on the hinge "clicks" into place. Repeat the procedure for the shorter sections. (Fig. 4-5)

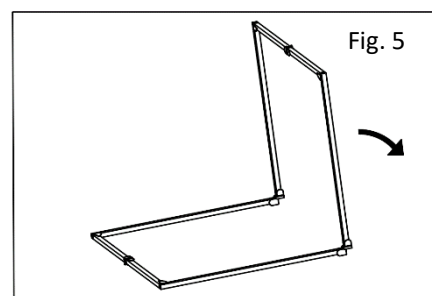
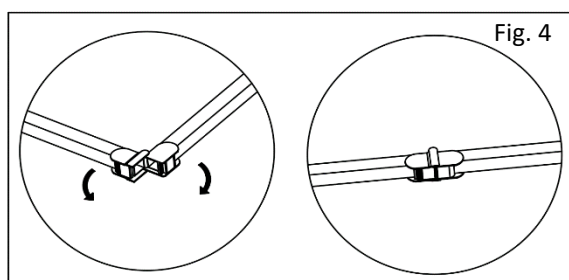

3. Make sure all 4 corners of the frame are at a 90° angle and the hinged support bar is straight and not bending (Fig. 6-7). After unfolding the frame, make sure to lay it out with the Velcro facing up (Fig. 8).

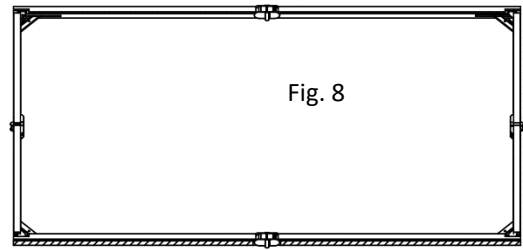
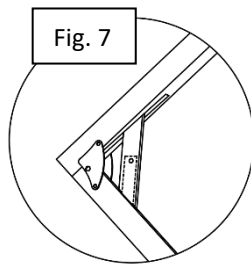
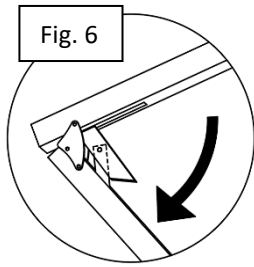

**CAUTION!**

THE PROJECTION FABRIC IS A DELICATE OPTICAL/LENTICULAR SCREEN MATERIAL AND SHOULD NOT BE FOLDED, BENT, OR CREASED. ALWAYS MAINTAIN SCREEN MATERIAL FLAT AND TAUT DURING SETUP AND DISASSEMBLY.

**IMPORTANT:** TWO PEOPLE ARE REQUIRED TO SETUP AND INSTALL THE MATERIAL TO AVOID PERMANENT DAMAGE. ANY DAMAGES TO THE SCREEN MATERIAL WILL VOID YOUR WARRANTY.

4. Carefully take out the screen material tube from the carrying bag and ONLY handle it HORIZONTALLY with two hands to avoid dropping it (Fig. 9).

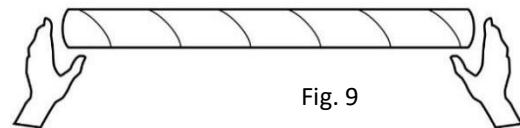

5. Once the screen material tube is on a flat surface horizontally, remove both end caps and gently pull out the screen material out of the tube. **DO NOT TRY TO SQUEEZE THE MATERIAL OUT OF THE TUBE TO AVOID IRREVERSIBLE PERMANENT BENDING/CREASING.**

6. Carefully unroll the screen material on a clean surface from the roller to the other side. (Fig. 10) place it on top of the frame with the projection side facing up (Fig. 11).

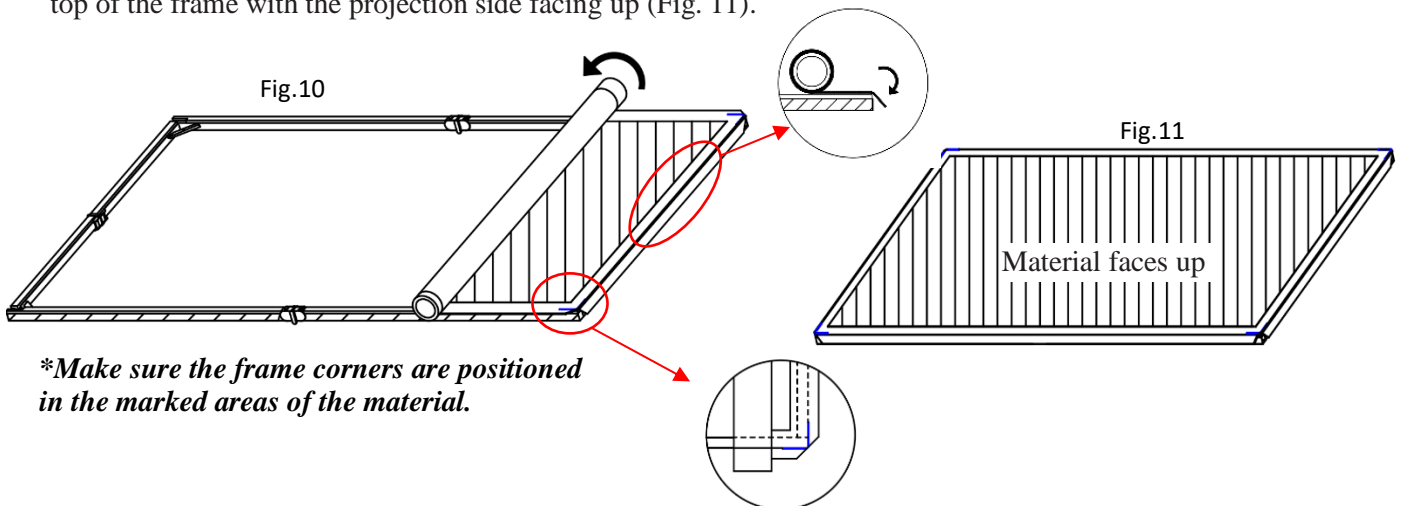

*\*Make sure the frame corners are positioned in the marked areas of the material.*

7. Begin attaching the material from the corners in the following sequence (Fig. 12).

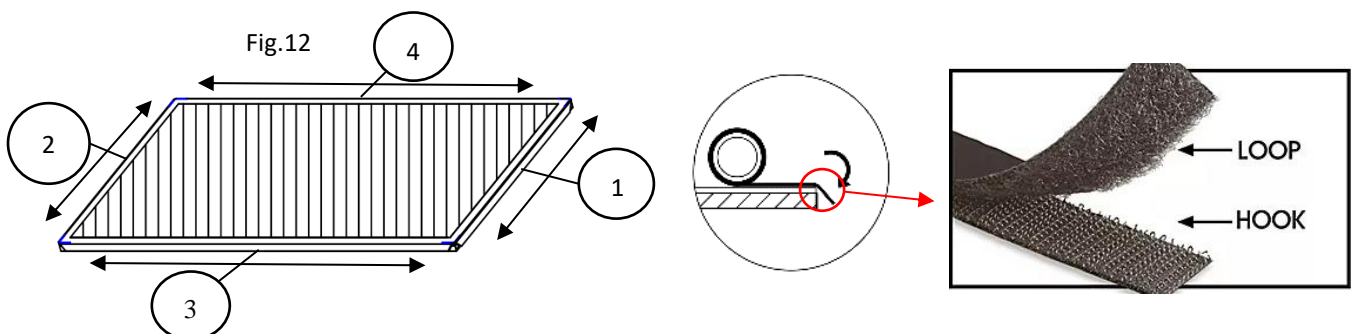

8. Lay the protective foam sheet on a clean flat surface and flip the screen over on the backside and place it on top of the sheet (Fig. 13).

Fig.13

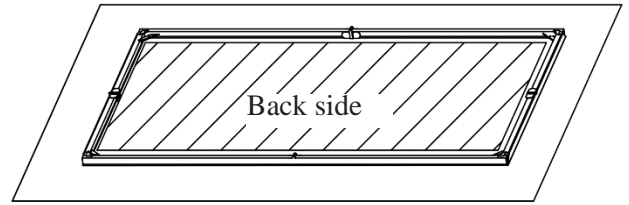

### LEGS ATTACHMENT

9. Carefully take the *folding legs* (B) out of the *carrying bag* (E) and place them on a flat surface.

**Warning:** The additional support sections, located at the middle section of the legs, may unfold on its own. Please be sure to use caution while removing/placing the legs from/to the bag.

10. Unfold the legs and position them on the back of the frame as shown below.

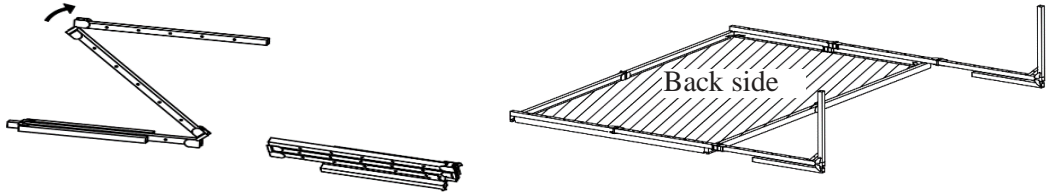

**Height adjustable feature:** The screen allows for the main frame to be set at various height intervals.

11. Lay the legs over on the back of the frame in the position desired.

Once you have aligned the leg's holes with the frame's holes, secure with the *knob screws* (F).

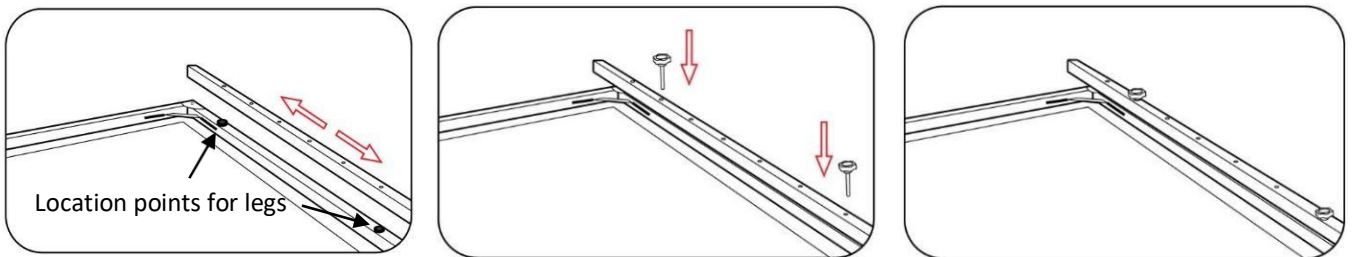

12. Next, lift the screen up while simultaneously opening the front frame legs. Two people are needed for this step.

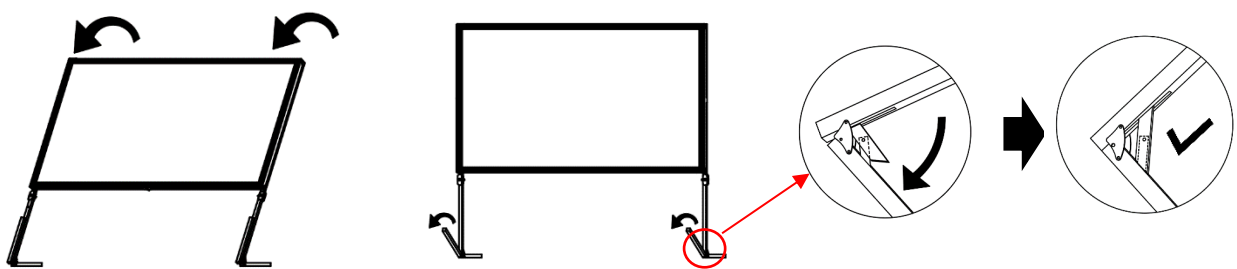

13. Full screen assembly is now complete.

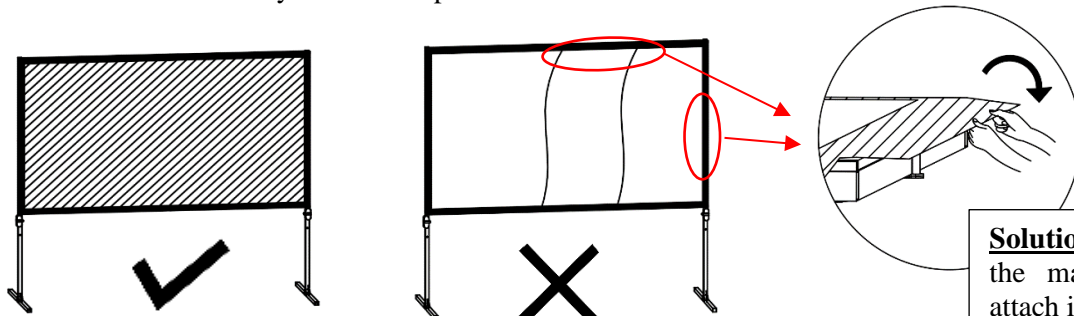

Screen material uneven or wavy?

**Solution:** Pull the edges of the material outward and attach it again.

## DRAPE/SKIRT INSTALLATION

14. Fasten the skirt(*H*) on the skirt hook (*I*), then attach along the bottom of the frame as shown below.

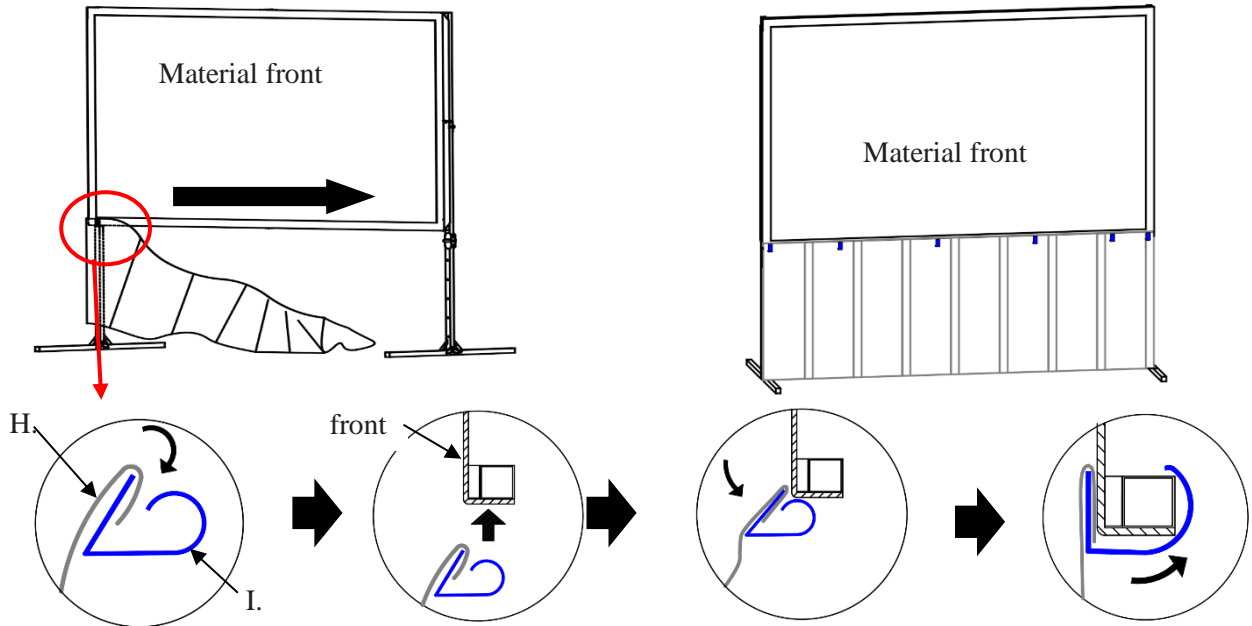

### Notice to Installer:

Please use the following installation instructions to obtain superior optical performance from the StarBright CLR® 16 (Ceiling/Ambient Light Rejecting) Screen.

Make sure to follow these instructions for the StarBright CLR® 16 to perform correctly.

1. Ambient Light must not come from the same direction as the projector's light
2. For best results, standard throw projector must have a lens throw of ratio 1.35 or greater.
3. **Not compatible with Ultra-short and Short-Throw Projectors**
4. **DO NOT install the projector higher or lower than the screen.**

**Tip:** Installing the projector in a 90-degree angle in the middle projection area will provide the best light dispersion for brightness uniformity.

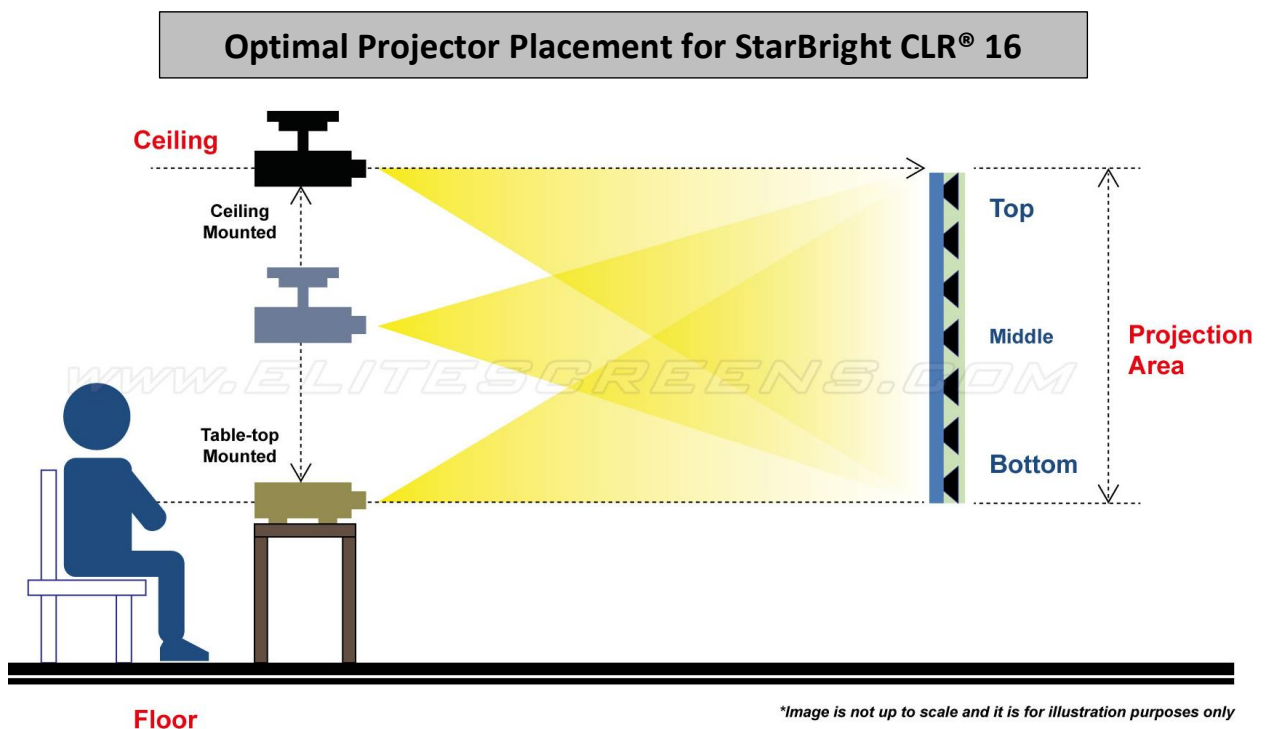

## Screen Disassembly

**TWO PEOPLE REQUIRED**

1. Lay the protective foam sheet on a clean surface and unhinge the front of each leg, then SLOWLY lower the screen down on the foam sheet.

**NOTE: Front side of the material should be facing down on the protective foam sheet.**

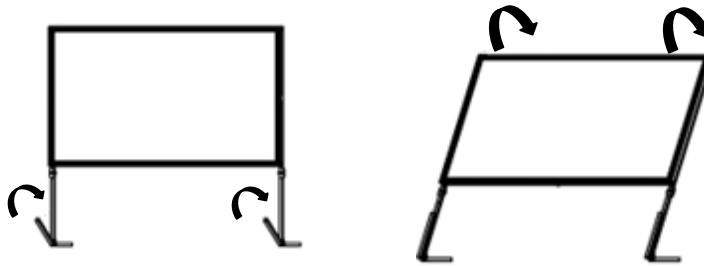

2. Once the screen is laid out on the protective foam sheet, unscrew all the knob screws on each side of the frame to remove the legs.

3. Next, turn over the screen so the front is facing up.

4. Unattach the material edges from the velcro on all sides. Then place the tube on top of the screen material and attach the edge of to the Velcro on the tube.

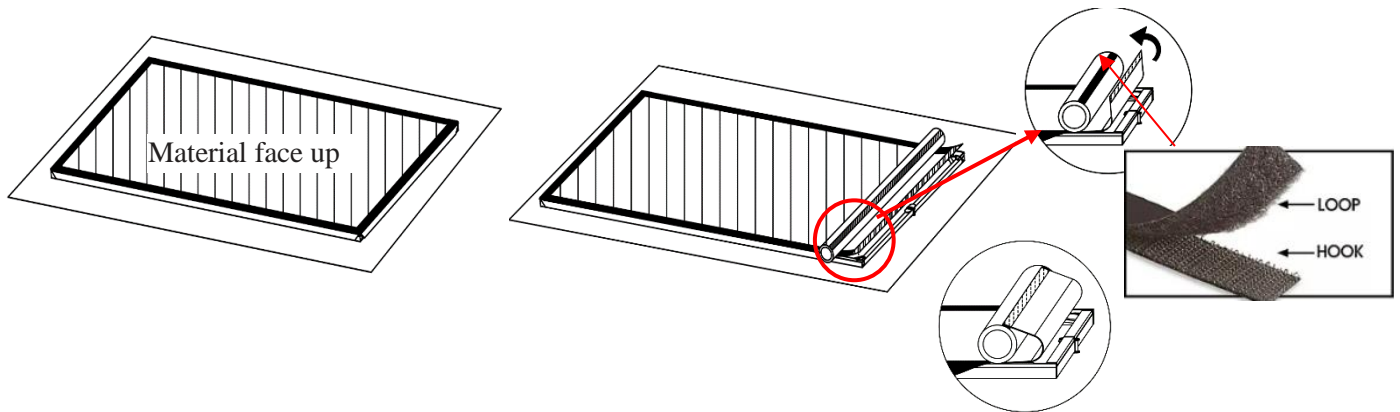

5. Slowly roll up the material on the tube and secure the ends.

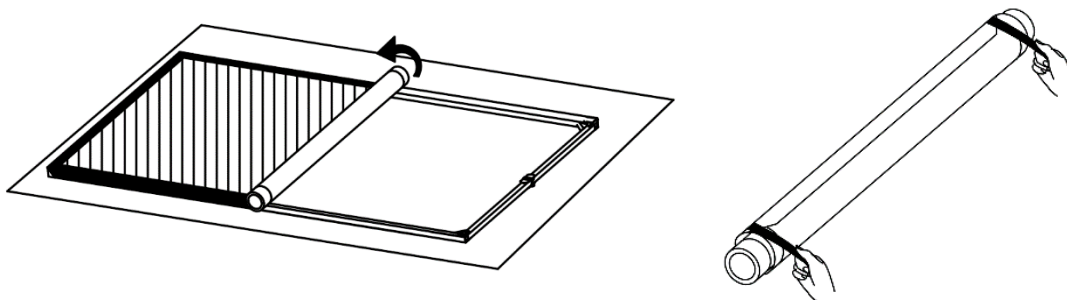

6. Then insert the material rolled on the tube into the bag.

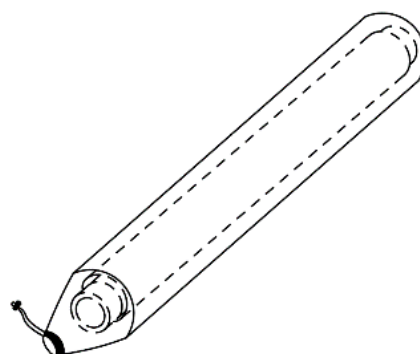



7. Once the material has been completely rolled, insert the rolled material with the outer tube lying horizontally. DO NOT force it in as that will crush the ends and damage the material.

**If the material does not fit in snugly, re-roll the material.**

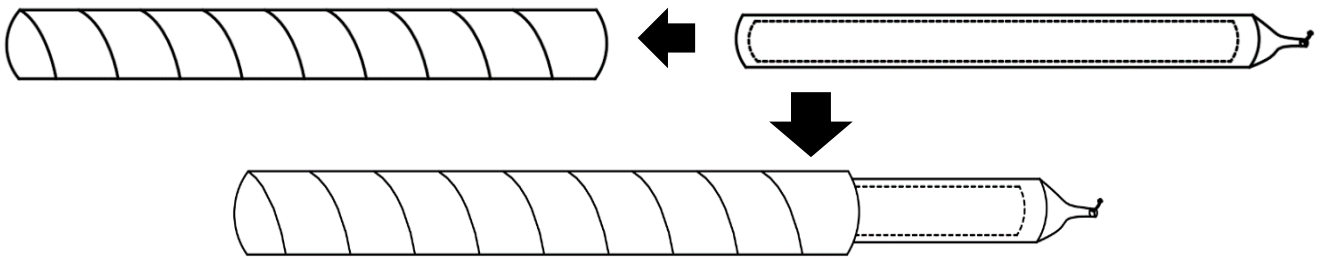

8. After the material is completely inside the outer tube, put the end caps back on to secure the material.

9. Unlatch the hinged support bars in each corner of the *folding frame (A)*.

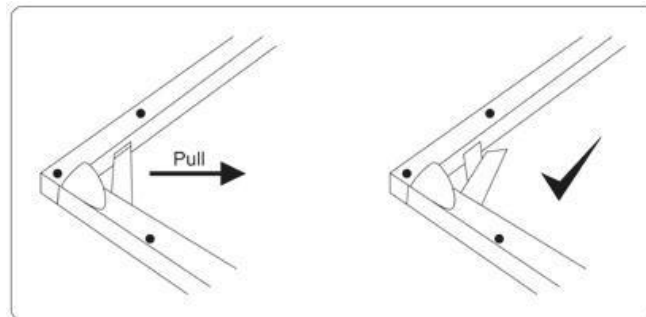

10. Press the locking buttons, near the folding joints, and slowly gather the sides of the folding frame.

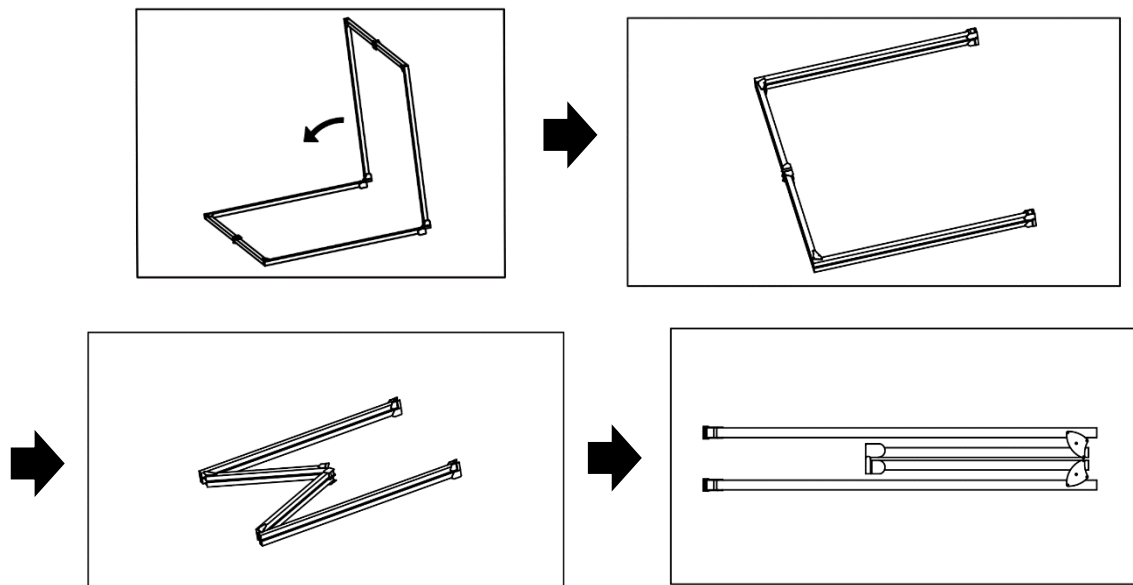

11. Again, press the locking buttons. Then, pick up one end of the folding frame, and walk it to the other end, folding the longer sections in half.

12. Carefully place the screen and components in the provided *carrying bag (E)*.

For a local Elite Screens contact or Technical Support, please visit  
[www.elitescreens.com](http://www.elitescreens.com)