



Whiteboard Projection Screen

# **WhiteBoardScreen™ Universal Series**

User's Guide



# Parts List for WhiteBoardScreen Universal

Please make sure all parts listed are included before proceeding with installation

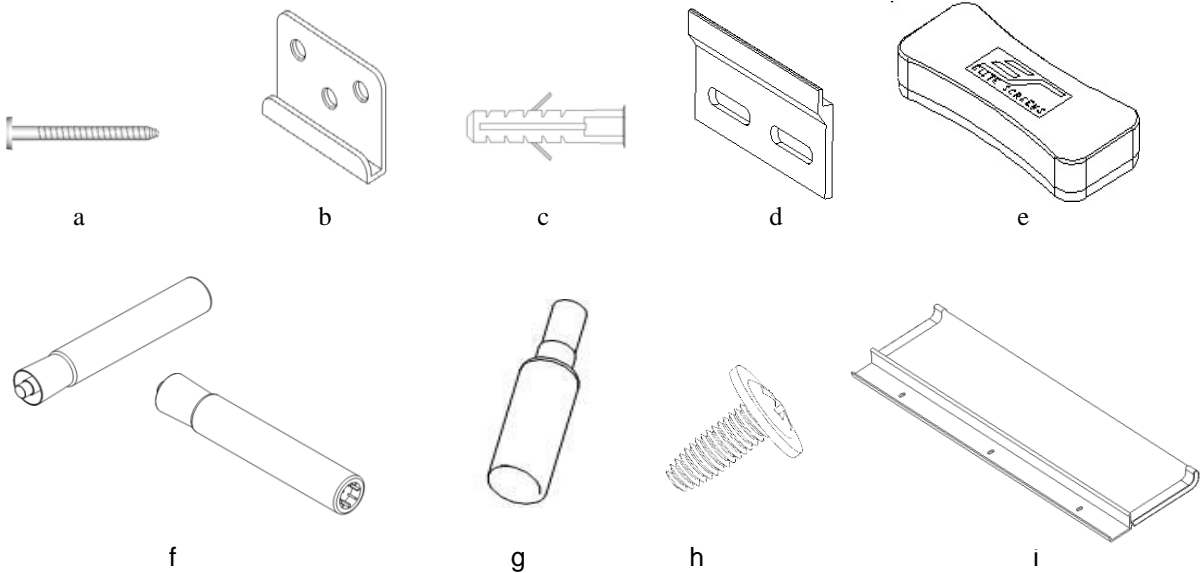

Parts List	QTY
a. Wall screws	12
b. Bottom hanging brackets	2
c. Hollow wall (drywall) anchors	12
d. Top hanging brackets	2
e. Eraser	2
f. Dry-erase markers	2
g. Cleaning solution	1
h. M3 Philip screws	3
i. Tray	1

**Note: The WhiteBoardScreen Universal Series eraser should only be used for the Elite Screens Whiteboard.**

## Installation

1. Mark the location the WhiteBoardScreen Universal will be installed and drill your holes for all of the Top Hanging Brackets (d). Once the holes have been drilled, insert and screw the wall screws (a) as shown below. It is strongly recommended to install the WhiteBoardScreen Universal on wood studs for added stability. If the location does not have wood studs, then use the included hollow wall (drywall) anchors (c).

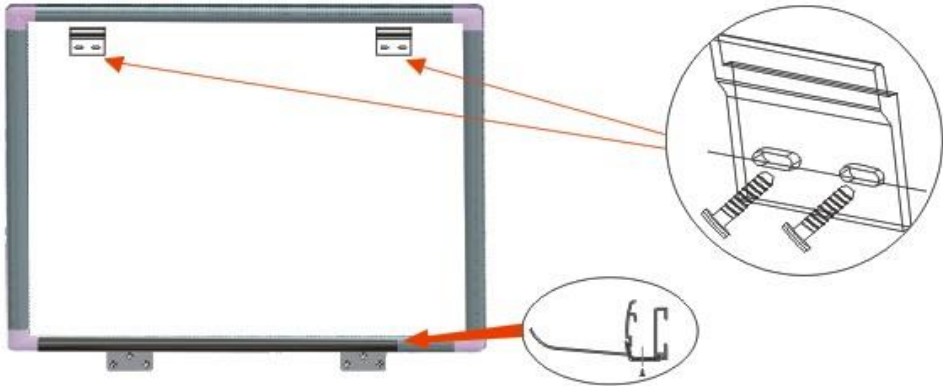

2. Next, attach the **tray** (i) to the bottom of the WhiteBoardScreen Universal with the three **M5 screws** (h) as shown below.

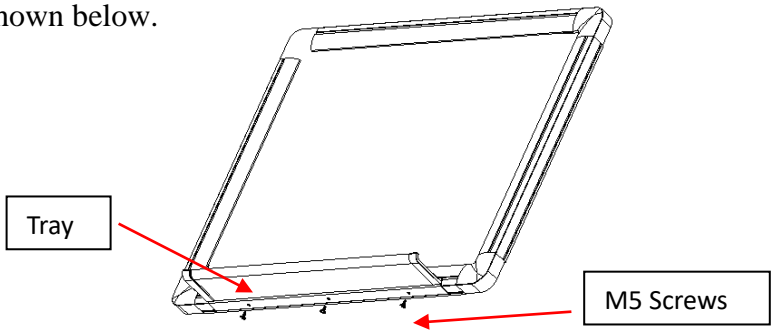

3. Hang the WhiteBoardScreen™ Universal on the **Top Hanging Brackets** (d), making sure the top lip inserts into the rail on back of the frame.

4. Next, attach the **Bottom Hanging Brackets** (b) to the bottom frame, again making sure the lip of the bracket inserts in the rail.

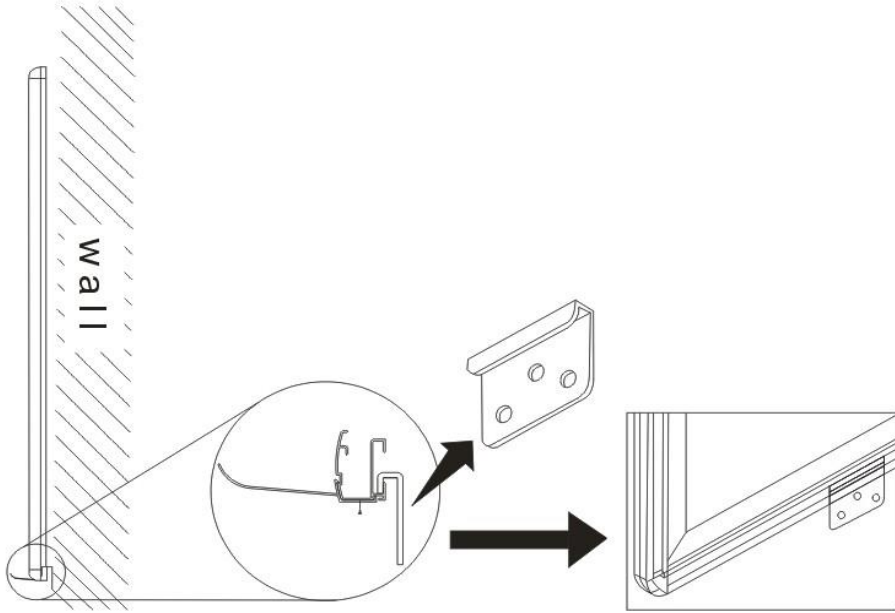

4. Drill and insert the **hollow wall anchors** (c) into the drilled holes, and then screw the bottom hanging bracket to wall.

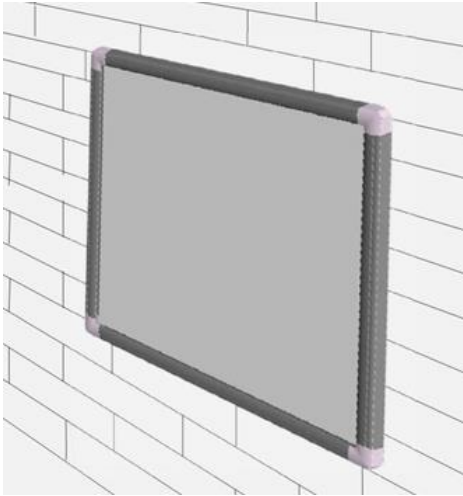

## Overhead Projector Installation

Unit: mm									
Models	Overall Width (W)	Overall Height (H)	Installation Height (A)	Suggested Projection Distance (B)	Ceiling Height (C)	Suggested Offset (D)	Viewer Distance (E)	Sitting View Height (F1)	Standing View Height (F2)
WB30VW	610.0	457.2	2340	1500-2500	2500	174	1200	1200	1700
WB58VW	1178.0	884.0	2340	1950-2950	2500	130	1200	1200	1700
WB77VW	1565.0	1174.0	2340	2750-3750	2500	174	1200	1200	1700
WB87XW	1874.0	1174.0	2340	2750-3750	2500	174	1200	1200	1700
WB94HW	2081.0	1170.0	2340	3200-4200	2500	29	1200	1200	1700
Unit: Inches									
Models	Overall Width (W)	Overall Height (H)	Installation Height (A)	Suggested Projection Distance (B)	Ceiling Height (C)	Suggested Offset (D)	Viewer Distance (E)	Sitting View Height (F1)	Standing View Height (F2)
WB30VW	24.0	18.0	92.1	59-98.4	98.4	6.9	47.2	47.2	66.9
WB58VW	46.3	34.8	92.1	76.8-116.1	98.4	5.1	47.2	47.2	66.9
WB77VW	61.6	46.2	92.1	108.3-147.6	98.4	6.9	47.2	47.2	66.9
WB87XW	73.8	46.2	92.1	108.3-147.6	98.4	6.9	47.2	47.2	66.9
WB94HW	81.9	46.0	92.1	126-165.3	98.4	1.1	47.2	47.2	66.9

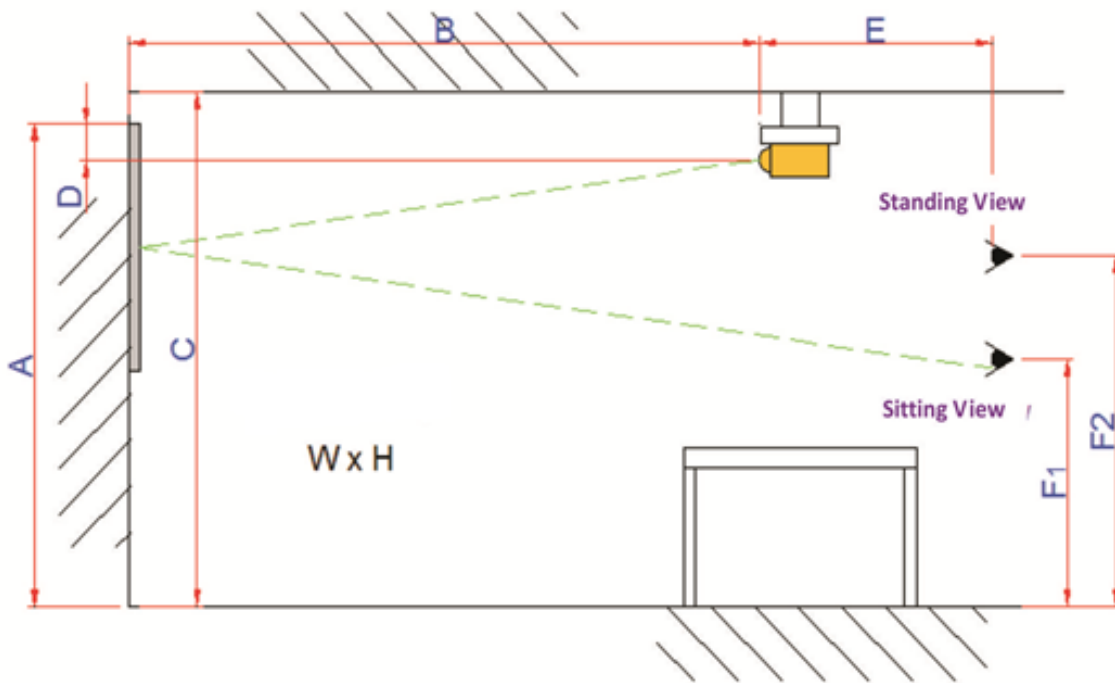

## Warranty Policy

- **Two (2) year** parts and labor warranty from defects in workmanship from purchase date as follows (except for refurbished units as specified below):
- **Three (3) year** parts and labor warranty from defects in workmanship for **GEMR** (Government, Educational, Military, & Religious) purchases of new product only.
- **Refurbished units** carry a **90-day** parts and labor warranty.
- Each party will be responsible for one way shipping during the warranty period.
- **A RMA (Return Merchandise Authorization) number** must be issued in order to process a replacement or to authorize a return for warranty repair. Elite Screens will, at its sole option replace or repair the defective unit with a replacement \*(see exceptions below) after the defective unit is received. Once the product is received, Elite Screens will send out a replacement \*unit to the customer by ground service (subject to inventory availability).
- **Do not return any unauthorized items to Elite Screen, as they will be refused and returned at your expense. The RMA number must be included on the outside label of your shipping box. Our warehouse is not authorized to accept returns without an RMA number on the shipping label.**
- **RMA numbers are valid for 45 days from the date of issue.**
- **Missing Parts** must be reported within 7-days of receipt. If reported after 7 days, customer will only be responsible for shipping and handling fees. If reported after 30 days of receipt, customer is responsible for cost of the parts and shipping & handling fees.

\*A new or refurbished replacement will be sent out to the customer depending on the type of purchase (new or refurbished) or based on stock availability.

### North America only, U.S. and Canada

For Warranty and Service requests please fill out a RMA /Service Form at:

[http://www.elitescreens.com/service\\_form](http://www.elitescreens.com/service_form)

Please Visit this link for full Warranty information:

<http://www.elitescreens.com/warranty>

REMEMBER TO REGISTER YOUR PRODUCT AT

[WWW.ELITESCREENS.COM/REGISTER](http://WWW.ELITESCREENS.COM/REGISTER)