

INSTA-DEM SCREEN SERIES

Section 1: Screen Design

1.1 What is it for?

The Insta-DEM Screen is a pliable magnetic backed front projection screen with dry-erase capabilities. It is designed to provide a highly versatile installation for virtually any training environment.

** An important note is that a regular whiteboard is not designed for use with projectors. They have no color neutrality and the gloss from its writing surface gives too much glare. The Insta-DE Screen's VersaWhite material is comprised of an adhesive contour pad-backing for textured walls*

1.2 How does it work?

The Insta-DEM Screen is easily installed via its magnetic backing onto ferromagnetic surfaces. Its pliable design makes it easy to handle in shipping and installation.

1.3 Sizes Available

52" and 69" diagonal in 4:3 aspect ratio

78" diagonal in 16:10 aspect ratio

85" diagonal in 16:9 aspect ratio

Section 2: Screen Material

2.1 Characteristics

2.1.1 Dry-Erase Front Projection Screen Material

VersaWhite performs as versatile Matte White projection screen material and a dry-erase surface as well. The surface is coated with a scratch-resistant nanotech resin that acts as a transparent dry-erase layer for use as a whiteboard while keeping diffusion uniformity and enhancing true color rendition.



2.1.2 Features & Benefits

- Gain: 1.1
- Viewing Angle: 180° (90° L/R)
- Cleans as easy as a standard whiteboard

- Contrast enhancements improve picture black levels for greater resolution and balanced color temperature
- Unique optical coating provides high diffusion uniformity and superior color reproduction
- **GREENGUARD Indoor Air Quality and GREENGUARD Children & Schools Certified**

2.1.3 Layout

VersaWhite Screen Material

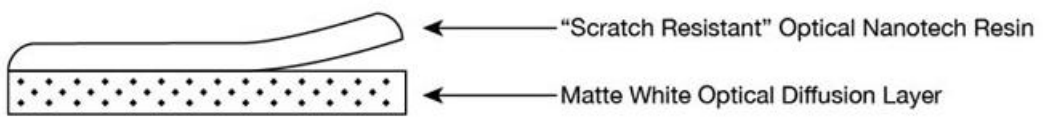

2.1.4 Gain Chart

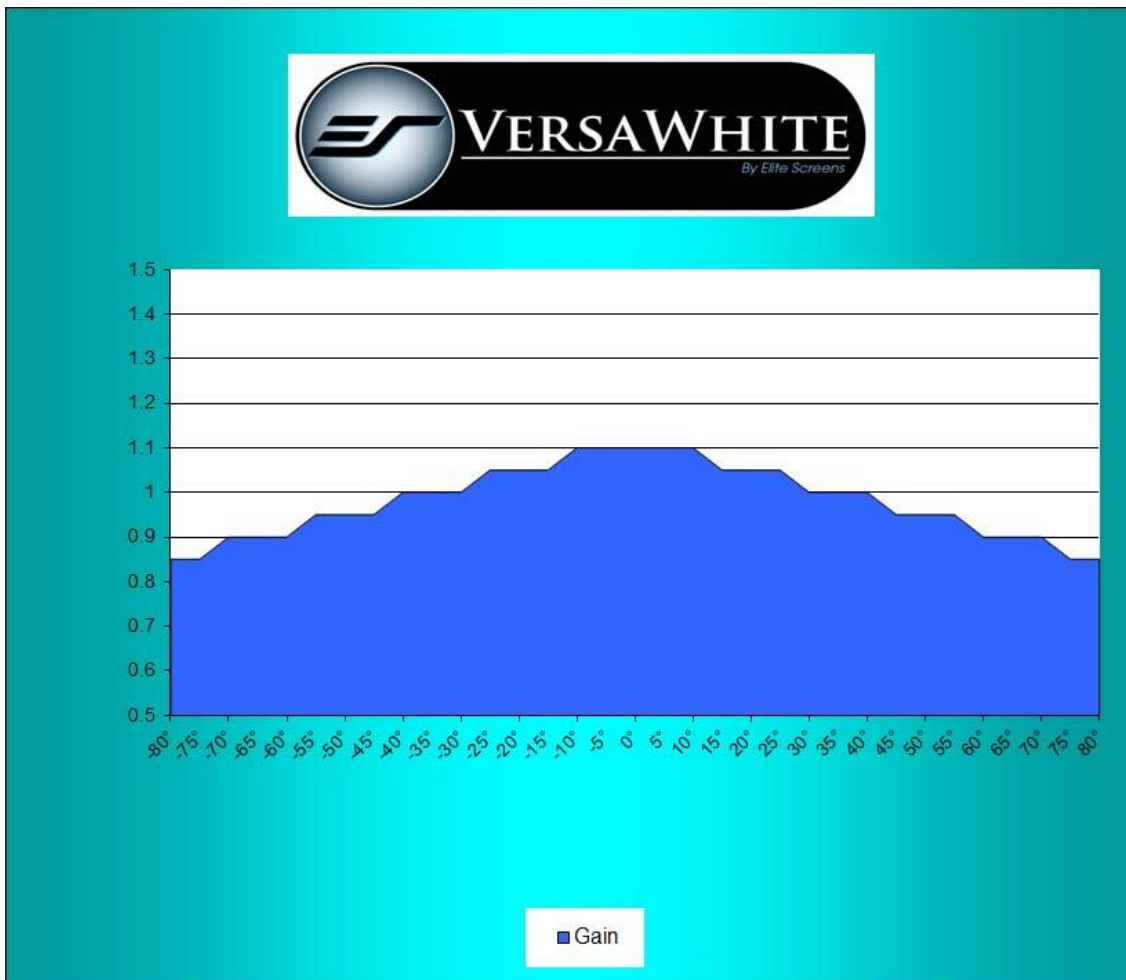

Section 3: Specifications

3.1 Dimensions

Unit : mm				
Model	Nominal Diagonal	View Height (A)	View Width (B)	Thickness (C)
iWB52VWM	52"(4:3)	788	1050	0.65
iWB70VWM	69"(4:3)	1050	1422	0.65
iWB78XWM	78"(16:10)	1050	1680	0.65
iWB87HWM	87"(16:9)	1050	1866	0.65
Unit : inch				
Model	Nominal Diagonal	View Height (A)	View Width (B)	Thickness (C)
iWB52VWM	52"(4:3)	31.0	50.0	0.0255
iWB70VWM	69"(4:3)	41.3	56.0	0.0255
iWB78XWM	78"(16:10)	41.3	66.1	0.0255
iWB87HWM	87"(16:9)	41.3	73.5	0.0255

3.2 Drawing

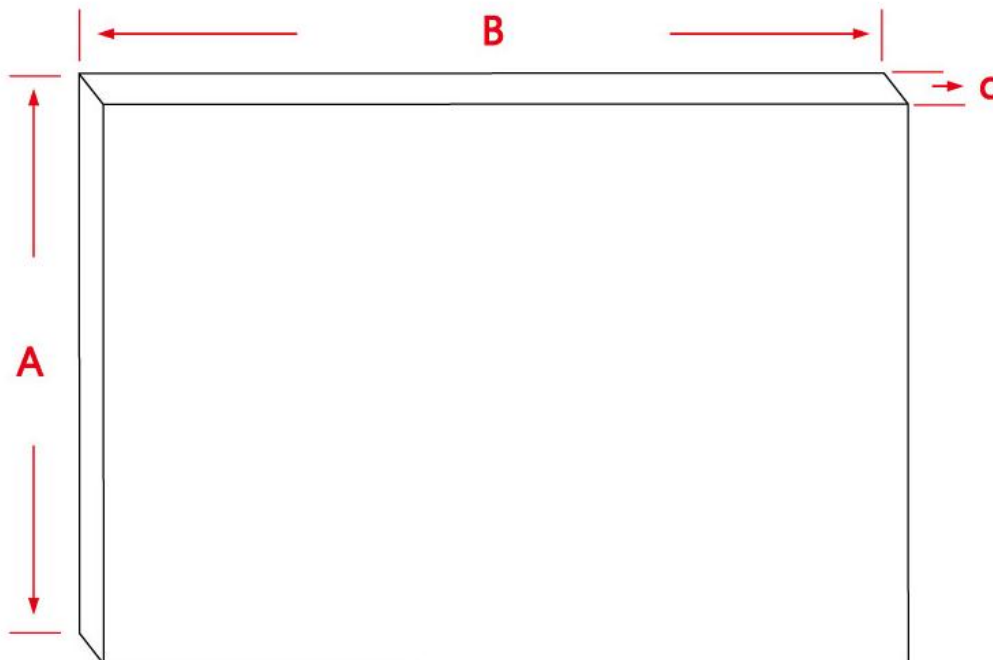

3.3 Pictures

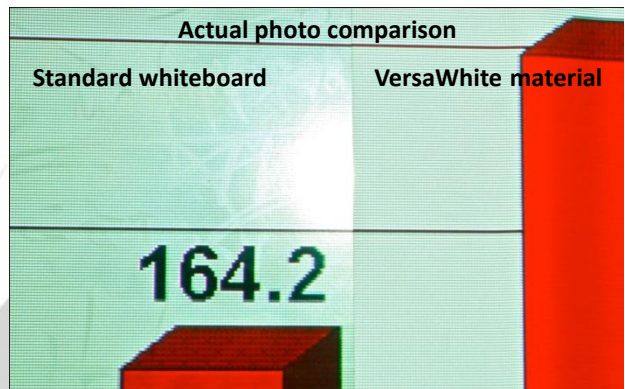
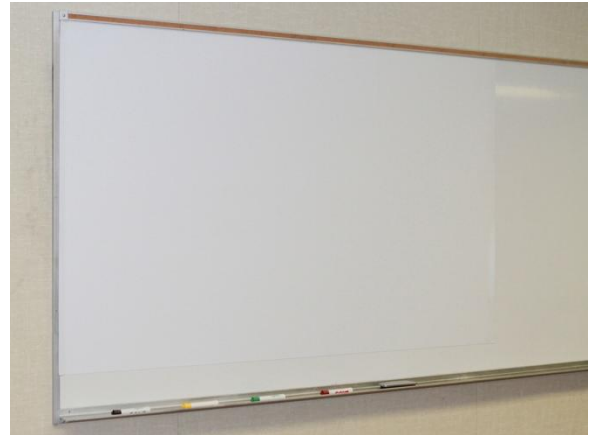

Section 4: Execution

4.1 Submittals

- Insta-DEM rolled up projection screen
- Users Guide
- Pens
- Erasers
- Self-stick cradle
- Magnetic bar

4.3 Installation

1. Clean the magnetic surface location where the **Insta-DEM Screen** will be installed.
2. Measure and mark the top-right and bottom-right corner of the installation position.

3. Attach the **Insta-DEM Screen** to the top-right and bottom-right corner of the location.

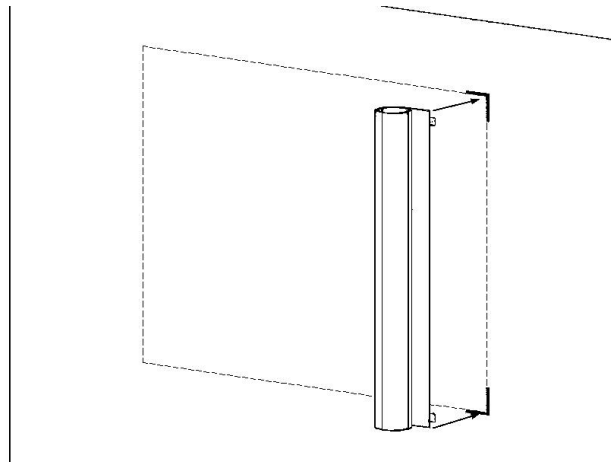

4. Carefully unroll the material and firmly attach the top and bottom until the Insta-DEM screen is completely attached.

Note: Prolonged storage of the Insta-DEM in its factory packaging *may result* in the material not being able to lie flat once removed from its tube. An easy way to remedy this is to remove the material from the tube and roll it up in a reverse manner for 5 minutes. This will flatten out the material and make it more pliable to work with. In addition, please use the included magnetic strip bars and attach them both to the left and right side ends to help the material stay flat.



Section 5: Markets With Product Availability

5.1 Where

America: Elite Screens Inc

info@elitescreens.com

www.elitescreens.com

Europe: Elite Screens GmbH

info@elitescreens.eu

www.elitescreens.eu

Asia: Elite Screens China Ltd.

info@elitescreens.com.cn

www.elitescreens.com.cn

France: Elite Screens France S.A.S

info.fr@elitescreens.com

www.elitescreens.com/fr

Asia: Elite Screens Taiwan Corp.

info@elitescreens.com.tw

www.elitescreens.com.tw

Asia: Elite Screens Japan

info@elitescreens.com.jp

www.elitescreens.jp



5.2 Company Description

Elite Screens Inc. is a California based company that specializes in making quality commercial and home-theater projection screens for the retail and custom install sales channels. Our company began as an innovative venture into the projection market by manufacturing veterans from the AV/IT industry. Elite Screens quickly established itself as an entry level commercial and home theater screen manufacturer. This was accomplished by making a quality product cost effective with a focus on mass-producing screen material, sizes and aspect ratios that were most commonly preferred by AV customers in general. We focused on uniformity with what would match the mainstream demographic while including extra features that are not usually included by other manufacturers. In time, we progressed from just retail sales into the realm of custom installer/integrator manufacture as our numerous reviews and awards will attest. We stand behind our product and are so certain of customer satisfaction with the quality of our product that we offer a 2-year manufacturer's warranty which is twice the industry standard.

In our continued devotion to excellence in products and service, we are committed to implementing green practices with our production. We have adopted manufacturing methods that promote conservative regulation of our energy needs. Our simple product designs combined with the expertise of our permanent staff ensures that our entire line of products are made by experienced hands devoted to the high standards of today's audio-video consumer.

###