



Electric Wall/Ceiling Projection Screen
Starling Tab-Tension 2 CineGrey 5D®
(White Case Models) User's Guide

Important Safety & Warning Precautions

Make sure to read this user's guide and follow the procedures below.

Caution: The screen's Black Top Drop is already set to its maximum drop distance. There is NO extra Black Top Drop in the roller. Please be aware of this as it will void your warranty with Elite Screens. Unapproved changes or modifications (except for cutting the power cord for hardwire installations) to this unit are prohibited and will void your warranty. For more information, please contact our Technical Support Department at (877) 511-1211 Ext. 604.

- Please retain this user's guide for future reference.
- To avoid damaging the unit, do not use with any unauthorized accessories not recommended by the manufacturer.
- Handle the unit carefully during transportation to avoid any damages.
- To ensure safe and reliable operation, direct connection to a properly grounded power source is advised.
- The power outlet supplying power to the unit should be close to the unit and easily accessible.
- Do not install the unit on uneven or inclined surfaces.
- Do not put heavy objects on the power cord and position it properly to avoid creating a trip obstacle.
- Never overload the power cord to prevent an electric shock or fire due to a loose contact or a short circuit.
- There are not user serviceable parts in this unit. Do not attempt to disassemble this unit by yourself. No one except authorized technicians can open and make repairs to this unit.
- Make sure the power source this unit is connected to has a continuous power flow.
- If there is need to use an extension cord, make sure the cord has an equal rating as the appliance to avoid overheat.
- Do not handle the power plug when your hands are wet or your feet are in contact with water.

Do not use this unit under the following circumstances.

- Disconnect the power cord under the conditions of heavy rain, wind, thunder or lightning.
- Avoid direct Sunshine, rain shower and moisture.
- Keep away from fire sources and high temperature to prevent this device from overheating.
- Cut off the power supply first before transportation or maintenance.
- Fully disconnect from the power supply when the unit is not in use for a long period of time, as should be done with any other electric household appliance.
- To avoid possible injury and/or an electric shock, do not attempt to use the screen if there is obvious damage or if there are any evident broken parts.

WARNING

The Screen's **Top Black Drop** is already set to its maximum drop distance. There is **NO** extra top black drop in the roller. Please be aware of this as it will void the limitation of your warranty.

Individual modifications to this product are prohibited and will void the warranty with the manufacturer. Please contact Elite Screens Customer Service for any questions.

NOTE:

This equipment has been tested and found to comply with the limits for a Class B digital device, pursuant to Part 15 of the FCC Rules.

These limits are designed to provide reasonable protection against harmful interference in a residential installation. This equipment generates and can radiate radio frequency energy and, if not installed and used in accordance with the instructions, may cause harmful interference to radio communications.

However, there is no guarantee that the interference will not occur on a particular installation. If this equipment causes harmful interference to radio or television reception, which can be determined by turning the equipment off and on, the user is encouraged to try to correct the interference by one or more of the following measures.

- ✓ **Reorient or relocate the receiving antenna of the device which may cause interference.**
- ✓ **Increase the separation between the screen and the device's receiver.**
- ✓ **Connect the equipment into a different power outlet other than the device.**

Pre-Installation



1. Carefully unpack the screen.
2. Always handle the screen in a leveled position on a clean surface.
3. In order to protect the screen from exposure to stains, keep the screen out of contact with foreign particles such as dust, sawdust, and/or liquids.

NOTE

Regardless of the mounting method, the screen should be securely supported so that the vibration or pulling on the viewing surface will not cause the casing to become loose or fall. The installer must insure that the fasteners used are of adequate strength and suitable for the installation location. Included mounting screws are complimentary and may not be appropriate for all mounting surfaces. Use appropriate anchors to safely secure the screen to the mounting surface or consult with a professional installer.

Hardware Parts List

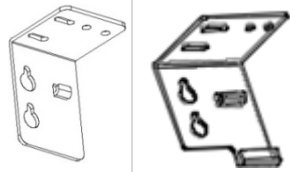
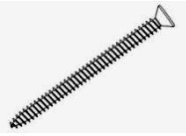
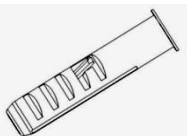
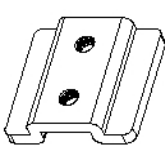
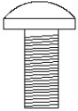
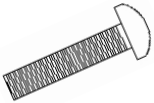
Please make sure all parts listed below are included before proceeding with the installation.

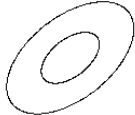
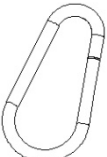
A. Wall/Ceiling mount bracket x2	B. M5x60 Screw x4	C. M12 Dry-wall anchor x4	D. Bracket connector x2	E. M5x11 Bolt Screw x4
 For 135" below For 135"-180"				
F. M5x25MM round head cross screws x2	G. M5x30MM eyebolt screw & M5 nut x2	H. Hidden wall bracket x2	I. R18xR6x1 washer x4	J. Snap link x2
				

Notice to Installer:

Please use the following installation instructions to obtain superior optical performance from the CineGrey 5D® Angular Reflective ALR (Ambient Light Rejecting) Screen.

Make sure to follow these instructions in order for the CineGrey 5D® to perform correctly.

- Angular-Reflective material is not compatible with ultra/short-throw projectors
- Minimum lens throw ratio 1.5x image width
- Ambient light must not come from the same direction as the projector

Since angular-reflective means that the projected image will reflect at the mirror-opposite angle, it is important to position the projector so that the viewer will get the best possible image.

Step 1: Establish the general “eye level” of the viewers

Step 2: Set the appropriate projection level

Step 3: Adjust the screen height level and projection angle

Input Angle (A) = Output Angle (B) aligns with the viewer’s angle

Correct Installation Examples

Projector Ceiling Installation: Make sure the projector (*light in*) is angled (A) to reflect (B) at the mirror-opposite angle (*light out*) to align with the viewer’s eye level.

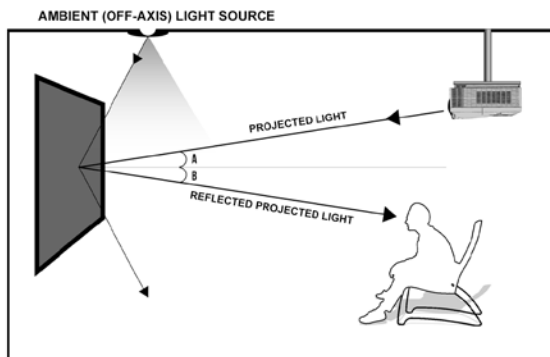

Projector Table Top: Make sure the projector (*light in*) is angled (A) to reflect (B) at the mirror-opposite angle (*light out*) to align with the viewer’s eye level.

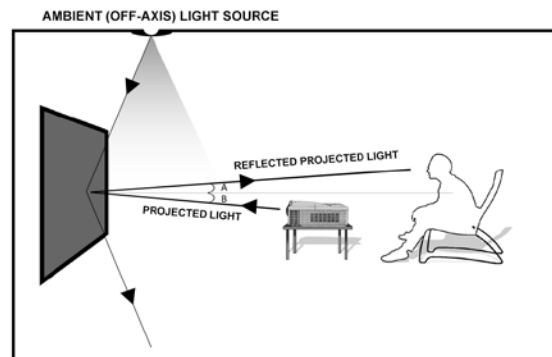

Incorrect Installation Examples

Ceiling Mounted Short-throw Projector

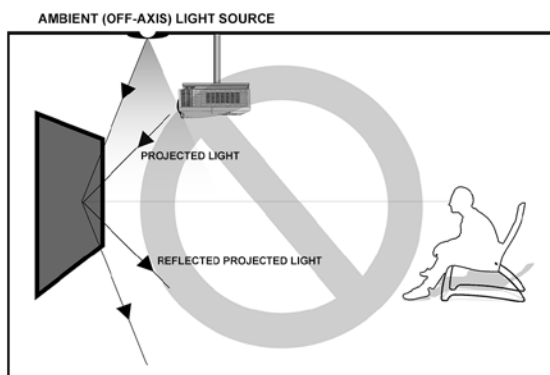

Tabletop Ultra-Short throw Projector

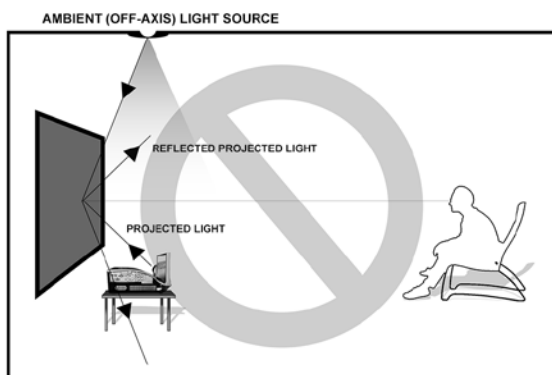

Note: Improper installation will result in light loss and produce a dark image. This is due to the projector’s light reflecting in the wrong direction.

Images are not up to scale and are for illustration purposes only.

Installation Instructions

For installation assistance, please consult a professional Installer. Elite Screens is not liable for faulty installations.

A. Wall Mount

I. Flush mount with wall/ceiling brackets (fixed position)

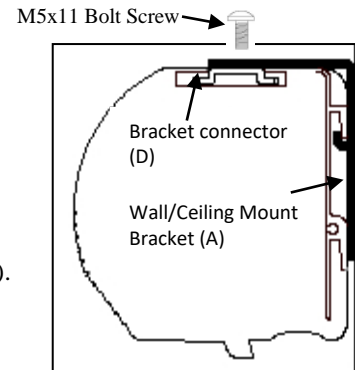
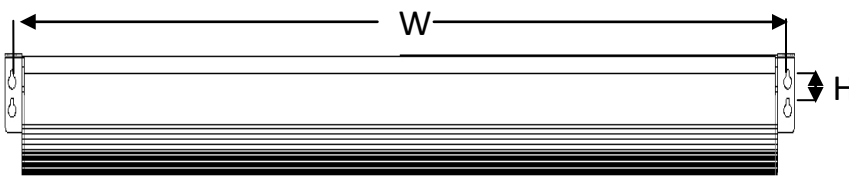

1. Begin by sliding the **bracket connector** (D) all the way to each end of the housing.
2. Then attach it to the **wall/ceiling mount bracket** (A) with the **M5x11 bolt screw** (E).
3. Measure and mark the (WxH) distance between the two holes on each bracket.
4. Drill a hole for each screw hole on the marked areas.
5. Insert a **dry-wall anchor** (C) into the wall.
6. Insert a **M5x60 Screw** (B) in each **dry-wall anchor** (C) and screw it in leaving about 1/8" of an inch.
7. Hang the screen by aligning the end cap holes to the **M5x60 screws** (B).

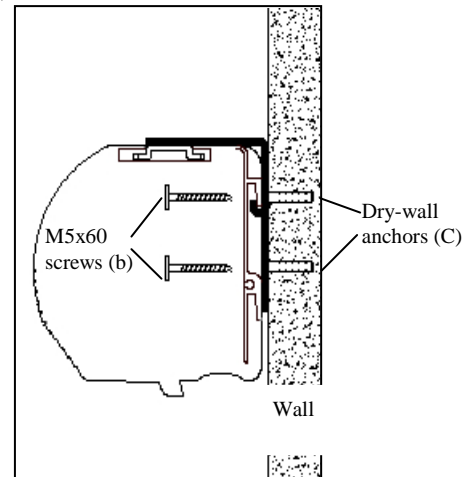
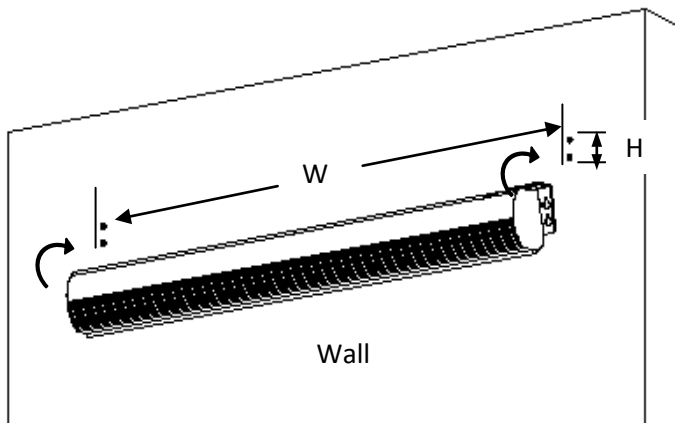

II. Flush hidden mount (movable position)

This mount method allows the screen to slide horizontally.

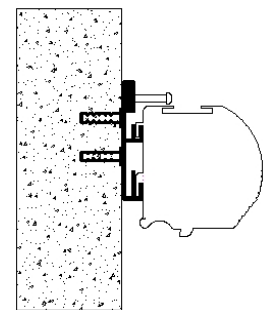
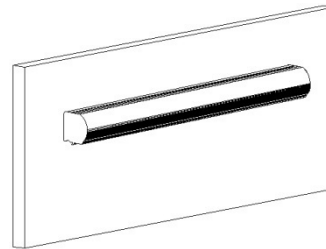
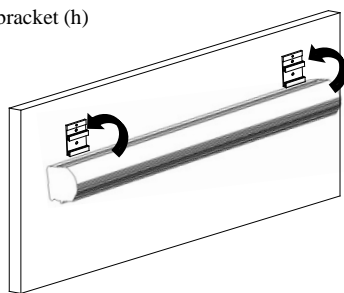
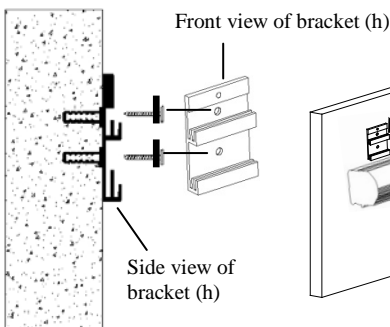

1. Determine where the screen will be installed. Then, measure and mark the distance between the top and bottom screw holes from each **hidden wall mount bracket** (H).
2. Drill a hole on all marked areas and install the brackets with the **dry-wall anchor** (C), **M5x60 screw** (B), and a **washer** (I). Make sure both brackets are properly leveled.
3. Hang the screen by placing the **downward** "catch" located on the back over the brackets **upper** "catch".
4. After making sure the screen is secured, you can slide it left / right to properly center it in position.
5. Lastly, screw the **M5 screw** (F) into the upper hole of the bracket to add additional support for the screen.

B. Ceiling Mount

I. Ceiling Mount(fixed position on end caps)

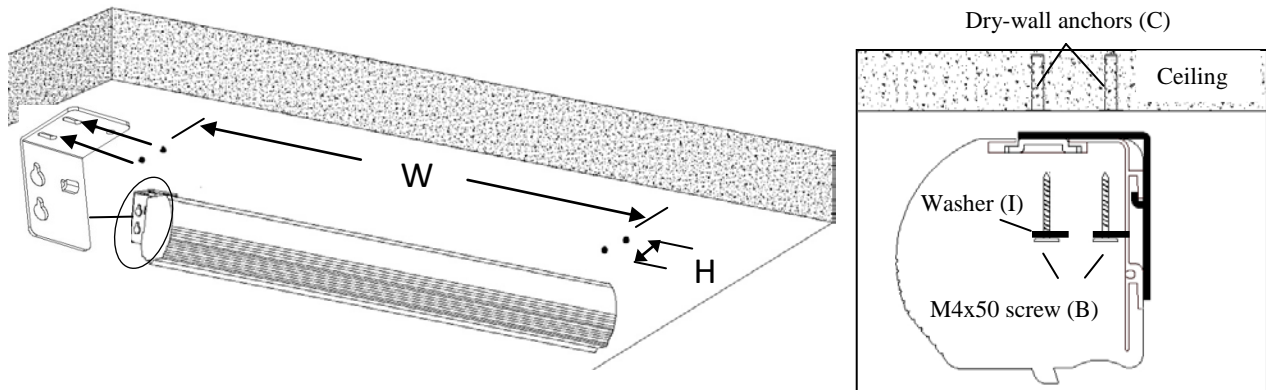

NOTE: The brackets do not slide. They are designed to attach the end caps only.

1. Attach the *Wall/Ceiling mount bracket (A)* to the *Bracket connector (D)* located on top of the screen's housing (preinstalled).
2. Determine where the screen will be installed. Then, measure and mark the distance between the (WxH) locations.
3. Drill a hole on all marked areas and insert a *dry-wall anchor(C)*.
4. Secure the screen by inserting the *M5x60 screw (B)* and a *washer (I)* thru the *wall/ceiling mount brackets (A)*.
Two or more people are required while one holds the screen in place.

II. Suspended

1. Screw the *eyebolt (G)* on the *bracket connector (D)*.
2. Attach the *snap link (J)* through the *eyebolt (G)* and connect it to an eyebolt screw (not included) rated for the screen's weight.

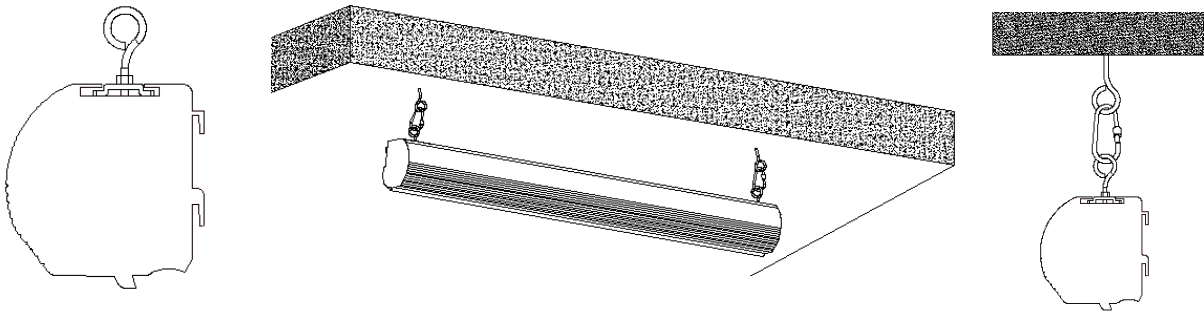





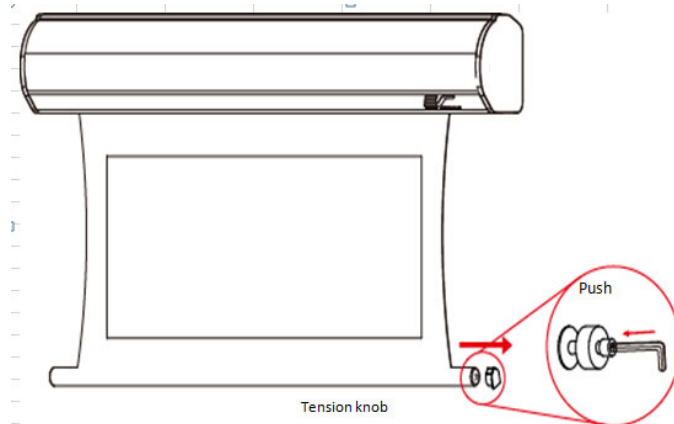

Screen material tension adjustment (4mm Allen Wrench required and not included)

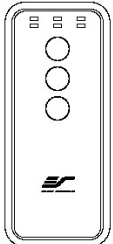
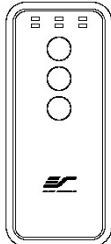
Remove the weight bar end cap to expose the adjustment tension knob. Insert your 4mm Allen Wrench to push in the adjustment tension knob, turn clockwise and your screen will gain more tension. Turn the Allen Wrench counter clockwise and the screen will lose tension. Please note this adjustment is not necessary as the tension of the screen has been set to its factory setting for best performance. Please contact Elite Screens for assistance to avoid damaging the screen and voiding your warranty.

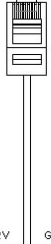

Starling Tab-Tension 2 CineGrey 5D® Series | Controls and Accessories

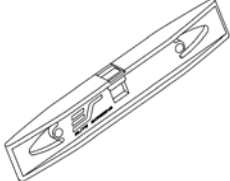
A. IR Remote	B. RF Remote	C. Wall switch control box	D. 5-12 volt trigger cable
			 Red 12V Green 0V
E. IR extended "eye" receiver	F. Wireless 5-12v trigger cable	G. AAA batteries	H. Bubble leveler
			

Screen operation

Electric Current: Depending upon region, your Elite Screens screen will operate on 100v, 110v or 220v voltage.

1. After ensuring the power outlet & screen are compatible (voltage), plug the power cord into the power outlet.
2. Once the screen has power, you'll be able to control it using any of the 6 methods described below.

6 ways to control your Starling Tab-Tension 2

1. **IR remote control (Item A, Fig 1):** The Infrared functions by direct line of sight contact with a beam range of 30 feet. Aim the IR remote at the circular window located on the left side of the screen.

2. **IR "Eye" Receiver (Item E, Fig 2):** The IR "Eye" Receiver plugs directly into the screen's RJ-45 input to present a low profile line-of-sight control option for your IR remote control even in a recessed ceiling installation.

3. **RF Remote Control (Item B):** The radio waves eliminate the need for a direct line of sight with a range of 100 feet.

4. **3-Way Wall Switch (Item C, Fig 3):** The 3-way wall switch is a wall mount control box with an up/stop/down button and plugs directly into the screen's RJ-45 input.

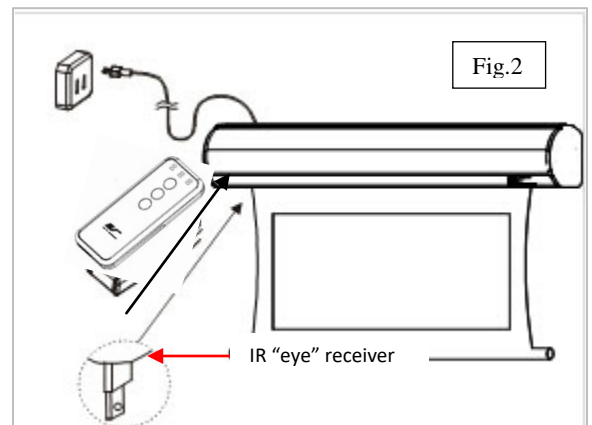
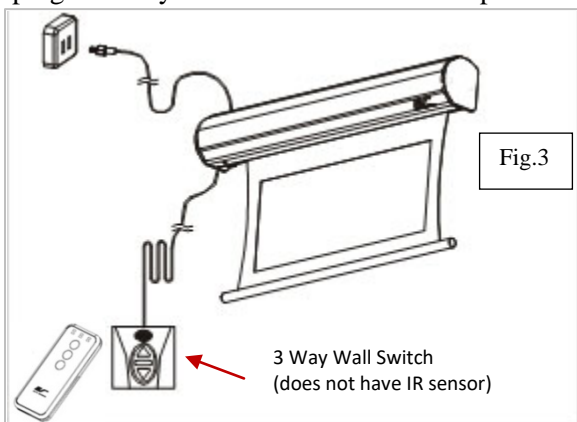
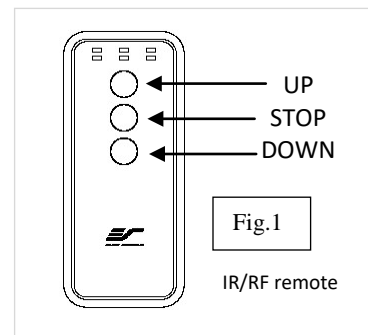

5. 5-12 volt trigger (Item D, Fig 4): The built-in 5-12V trigger input allows your screen to synchronize its drop & rise with the projector's power cycle. The screen deploys when the projector powers up and will retract when the projector powers down. The 5-12 volt RJ45 cable connects to your projector's trigger output via a separate cable that may or may not be provided by the manufacturer of the projector. The trigger feature will not work without an output cable from the projector, but it can be tested by connecting the Red (+) and Green (-) cable to a 9-volt battery.

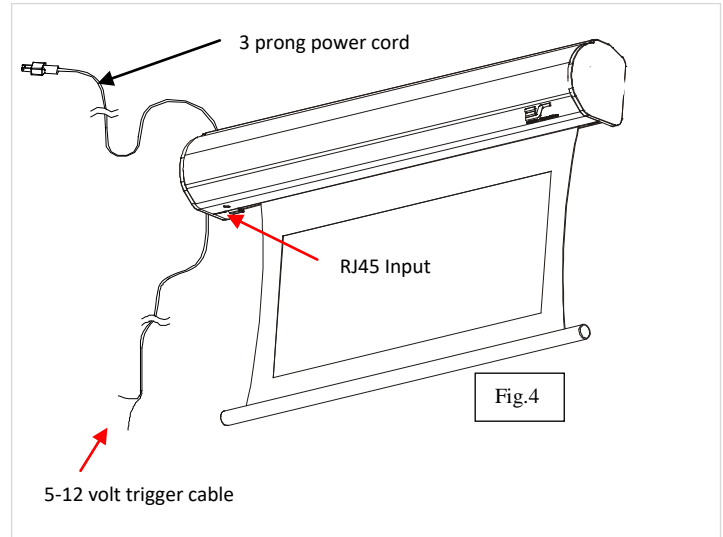

6. Wireless 5-12 volt trigger (Item F, Fig 5): The RF remote control serves as a dual purpose, independently as a handheld remote control, or in conjunction with the Wireless 5-12 volt trigger cable. The radio frequency technology can be programmed to send a wireless signal to synchronize its drop & rise with the projector's power cycle.

Here's how to set up your Wireless 5-12 volt trigger | Synchronization Instructions

- Step 1:** Connect one end of the 3.5 mm wireless 5-12 volt trigger cable to the RF remote.
 - Step 2:** Connect the other 3.5 mm end of the wireless 5-12 volt trigger cable to your projector.
 - Step 3:** Make sure to unplug your screen from the power outlet
 - Step 4:** Hold the UP button on your RF remote
 - Step 5:** While holding the UP button, plug the screen back to the power outlet
 - Step 6:** Wait 5 seconds and then release the UP button
 - Step 7:** Your 5-12V wireless trigger should now be activated with your screen and ready to be used and able to control your screen with your projector's power cycle
- Repeat the steps again if not successful.
 (Please be aware, the projector on/off cycle may take longer to fully activate. It usually takes around 20-30seconds for full off and on cycle each time)

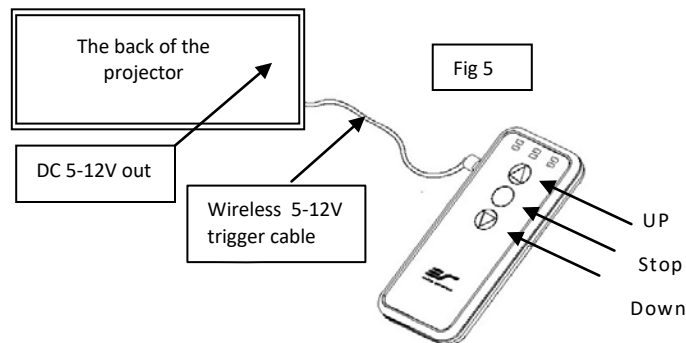

For more information, technical support or your local Elite Screens contact, please visit www.elitescreens.com